

# H3

## Falcon 4010

## User Manual



# Navigation

Device Allocation	<a href="#">P.14</a>
Firmware update	<a href="#">P.24</a>
GUI Introduction	<a href="#">P.7</a>
Hardware Installation	(Quick Installation Guide)
LCD Operation	<a href="#">P.34</a>
License Key Activation	<a href="#">P.31</a>
Operation Safety	<a href="#">P.45</a>
PCIe Port Configuration	<a href="#">P.16</a>
Rest to Default	<a href="#">P.44</a>
Service Parts	<a href="#">P.33</a>
Specifications	<a href="#">P.5</a>
System modes	<a href="#">P.6</a>
Trouble Shooting	<a href="#">P.46</a>

# Table of Contents

<b>1. Introduction</b>	<b>4</b>
1.1 Key Features	4
<b>2. Package Contents</b>	<b>4</b>
<b>3. Technical Specifications</b>	<b>5</b>
<b>4. Requirements</b>	<b>5</b>
4.1 Host Server	5
4.2 Host OS/BIOs	5
4.3 Web Browsers	6
<b>5. Hardware Installation and Initial Settings</b>	<b>6</b>
<b>6. System Modes</b>	<b>6</b>
6.1 Standard Mode	6
6.2 Advanced Mode	6
<b>7. Graphical User Interface</b>	<b>7</b>
7.1 Log-in	7
7.2 Functions	7
7.2.1 Overview	8
7.2.2 Resource Management	12
7.2.3 Port Configuration	16
7.2.4 Monitor	18
7.2.5 System Health	20
7.2.6 Chassis	23
7.2.7 Maintenance	24
7.2.8 Event Logs	26
7.2.9 Setting	27
<b>8. Parts Replacement</b>	<b>33</b>
8.1 Fans	33
8.2 Power Supply Units	33
<b>9. LCD</b>	<b>34</b>

9.1 Operation .....	34
9.2 Menus.....	35
9.2.1 Main menu .....	35
9.2.2 Power control.....	36
9.2.3 Power reset .....	36
9.2.4 System .....	36
9.2.5 Slot .....	37
9.2.6 Devices .....	38
9.2.7 Hosts .....	39
9.2.8 Health.....	40
9.2.9 Temperature.....	41
9.2.10 Network .....	41
9.2.11 Password (Feature coming Soon) .....	43
9.2.12 Reset to default.....	44
<b>10. Operation Safety.....</b>	<b>45</b>
<b>11. Trouble Shooting .....</b>	<b>46</b>
Symptoms or Errors .....	46
Solution .....	46

# 1. Introduction

Falcon composable GPU solution consists of Falcon Composable Chassis and the management GUI. The system is applicable to most multi-GPU applications and the software-defined approach greatly simplifies the device managements.

## 1.1 Key Features

- **GPU composability**
- **Device surprise-add and remove**
- **GPU peer-to-peer**
- **PCIe port configuration**
- **Real-time GPU cluster topology**
- **System performance monitoring**
- **Role-based authentication and access control**

## 2. Package Contents

- **Falcon 4010 GPU Expansion Chassis** \*1
  - Main chassis (1)
  - GPU drawer (2)
  - PSU (2)
  - Fan (6)
- **Power cord (PSU)** \*2
- **Mini-SAS HD external cable** \*8
- **Host bus adapter set** \*2
  - HBA (2)
  - Full-height bracket (2)
  - Half-height bracket (2)
- **PCIe power cable (8 to 8 pin)** \*8

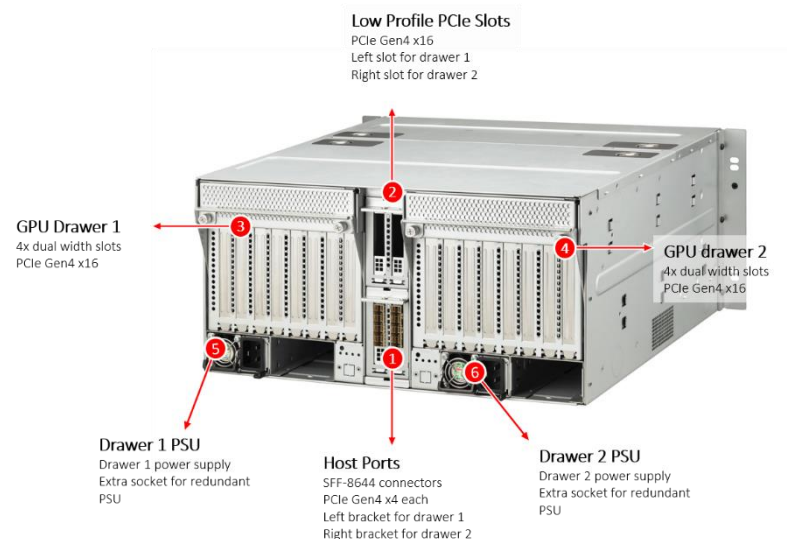

## 3. Technical Specifications

Chassis	
BMC/mCPU	Aspeed AST 2500
PCIe Switch	PEX 88096; PCIe 4.0
PCIe Slots*	8x PCIe4.0 x16 dual-width, FHFL 2x PCIe 4.0x16 low-profile
Host Interface	SFF-8644 connectors
Power	1600W; 220V AC; 80+ Platinum; hot swap
Fan	120x120x38mm; 6700 RPM; hot swap
Operating Temp.	0°C ~ 35°C (32°F ~ 95°F)
Dimension	5U; 219(H) x 435(W) x 450 (D) mm
Net Weight	34.5 kg
Mini-SAS HD external Cable	
Connector	SFF-8644 to SFF-8644
PCIe	PCIe 4.0 x4 each
Length	2 meters

\* Each PCIe slot supports up to 300 watts (75W from slot + 225W from the 8pin PCIe power)

## 4. Requirements

### 4.1 Host Server

Minimum of one vacant PCIe x16 (PCIe 3.0 or higher) slot for HBA installation.

### 4.2 Host OS/BIOs

#### Standard Mode:

No limitations

#### Advanced Mode:

Ubuntu	16.04 LTS, 18.04 LTS, 20.04 LTS
Windows	build 1903-20H2
Cent OS/ RHEL	7.3-8.0

#### Note:

Advanced mode is not limited to the OS listed above. The listed OS are recommended as they have been tested to support PCIe device hot plug.

## 4.3 Web Browsers

Mozilla Firefox	3.5 (or higher)
Google Chrome	ver. 12 (or higher)

# 5. Hardware Installation and Initial Settings

Please see *Falcon 4010 Quick Installation Guide* for system set up.

## 6. System Modes

There are two system modes for Falcon 4010. The **Standard Mode** is limited to single host connection and does not support device dynamic allocation or host port bifurcation. The **Advanced mode** supports multiple host connection and could allocated devices to hosts dynamically. You could activate the Advanced mode with a premium license key.

Please contact sales@h3platform.com for purchase.

### 6.1 Standard Mode

- System monitor
- Power control from GUI
- Download system performance data from GUI
- Firmware update
- User management
- **Limited to single host** (per GPU drawer)  
*\*Does not support device dynamic allocation and host port bifurcation*

### 6.2 Advanced Mode

- System monitor
- Power control from GUI
- Download system performance data from GUI
- Firmware update
- User management
- **Multiple host**
- **Device hot plug** (if the OS supports this feature)
- **Port configuration**
- **Device dynamic allocation**
- **Mode switch**

# 7. Graphical User Interface

## 7.1 Log-in

Every time you access GUI, you will be asked to log in.

Please enter your **username** and **password**.

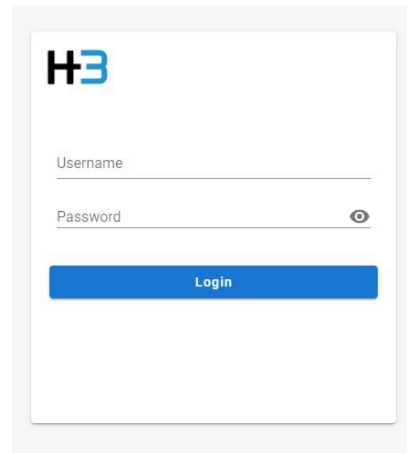

## 7.2 Functions

The drop-down menu is at the top-left of the page

Please find details of each function in the relative section.

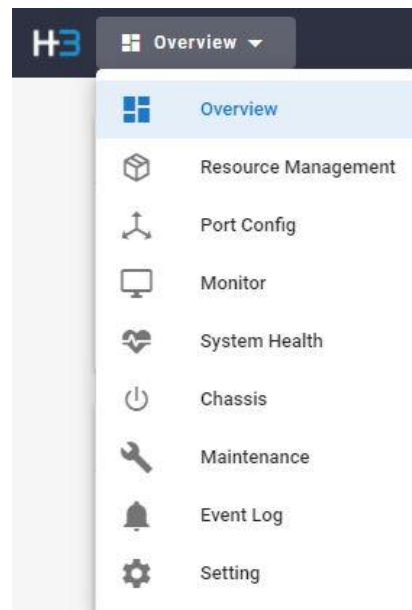



## 7.2.1 Overview

The overview page sorts out the basic performance data of the Falcon 4010 system in charts and graphs.

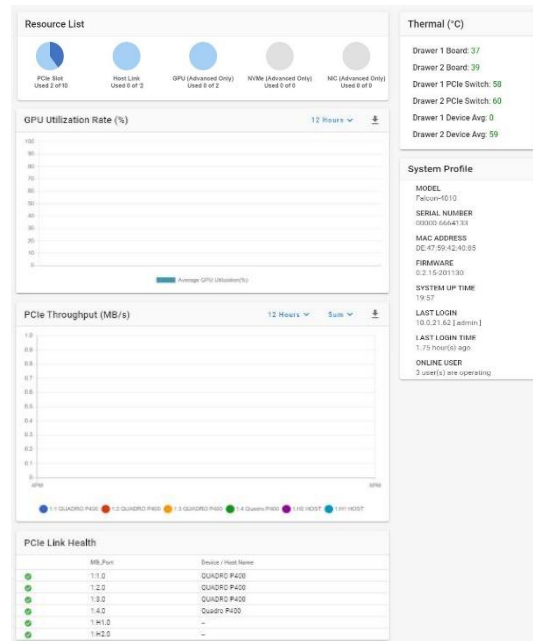

### Resource List

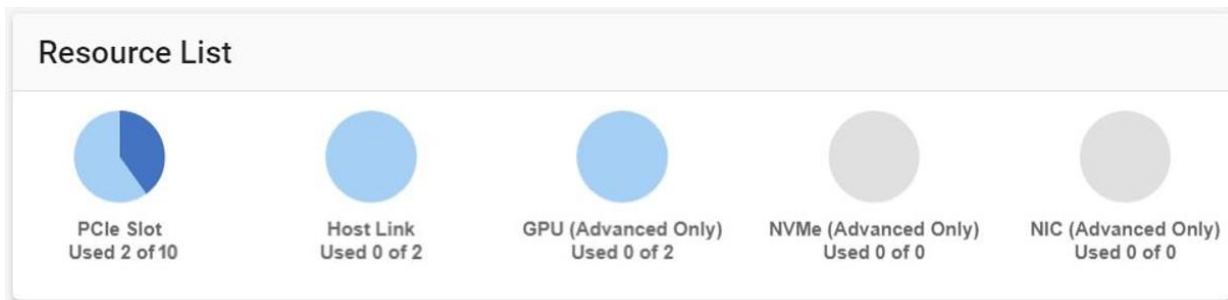

The Resource List provides PCIe device usage and host port usage information.

Usage of specific device types (GPU, NVMe, and NIC) features can be accessed with **premium license** activated.

“Used” indicates the number of devices that are currently assigned to hosts.

e.g. Used 8 of 10.

There are 10 devices installed in Falcon 4010, 8 of them are assigned to the host(s).

## GPU Utilization Rate(%)



In the GPU utilization chart, users can check the GPU utilization of a specific GPU in a specific period. Y-axis represents the utilization rate and X-axis represents a specific GPU. The data is read from PCIe devices directly, only the compatible devices with the out-band information will be shown here.

- Graph title:** GPU Utilization Rate(%)
- Utilization rate:** The average GPU utilization scaled from 0~100%
- Bar graph:** Utilization rate of a specific GPU displayed in bar graph
- Device number:** displayed as [Drawer#] : [Slot#]. E.g. 1:1 indicated GPU on drawer 1 slot 1.
- Display period:** The graph will display the utilization rate of the GPUs in the past hours. (1, 12, 24, or 72 hours options available)
- Download:** Download the GPU utilization data (up to the past 72 hours)

## PCIe Throughput(MB/s)

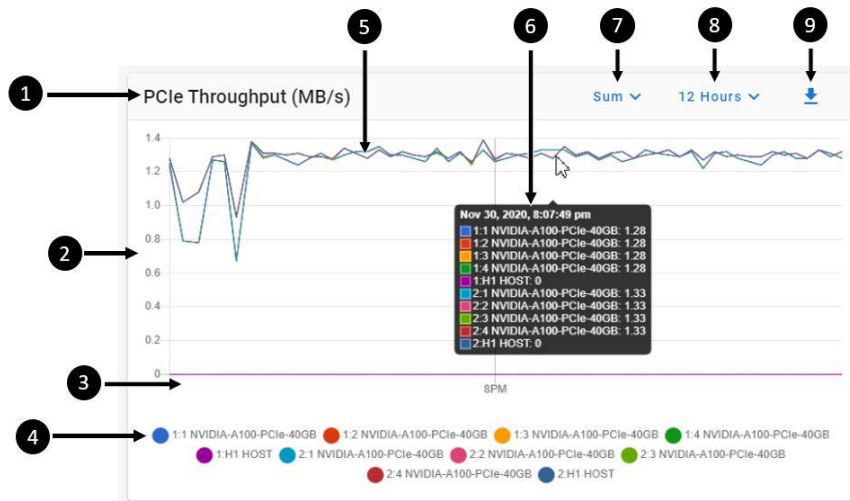

The PCIe Throughput graph shows the throughput of each device in MB/s. The data is read from PCIe devices directly, only the compatible devices with the out-band information will be shown here.

- Graph title:** PCIe Throughput (MB/s)
- Throughput rate:** The numbers on throughput rate scale (MB/s) will increase as throughput

increases.

3. **Time:** The X-axis display system times (per hour)
4. **Devices:** List all the devices installed. Every device has a unique color indicator.
5. **Throughput curve:** The curve of PCIe throughput of each device, distinguished by the color.
6. **List down menu:** Displays throughput of each device at a specific time point.  
Move the mouse over the curve to see this menu.
7. **Select Traffics:** Select traffic types to display on the throughput graph.  
There are three types: Ingress, Egress, and Sum.
8. **Display period:** The graph will display the PCIe throughput rates in the past hours.  
(1, 12, 24, 72 hours options available)
9. **Download:** Download the PCIe throughput data (up to past 72 hours)

## PCIe Link Health

Status	Port#	Port-Type	Name
✓	1:2.0	Device	QUADRO P400
✓	1:4.0	Device	QUADRO P400
✓	1:H1.0	Host	

The PCIe Link Health chart shows the link health condition of every PCIe port in use.

1. **Chart title:** PCIe Link Health
2. **Health indication:** **Green** indicates healthy (Bad TLP=0, Bad DLP=0)  
**Red** indicates errors existed (Bad TLP>0, BAD DLP>0)  
**Gray** indicates no link
3. **PCIe port number:** PCIe ports are listed in order.
4. **Port type:** indicates that whether the port is a device or host port
5. **Device name:** The name of the devices installed on the specific PCIe ports.

## Thermal(°C)

Thermal (°C)	
Drawer 1 Board:	37
Drawer 2 Board:	39
Drawer 1 PCIe Switch:	58
Drawer 2 PCIe Switch:	60
Drawer 1 Device Avg:	0
Drawer 2 Device Avg:	59

The Thermal chart displays the average temperature of each component (in °C) in the Falcon 4010 chassis is displayed.

- Green** Good thermal performance
- Amber** Moderate thermal performance
- Red** **Overheat. Please check out the system.**

*\* Falcon 4010 will shut down automatically when the system detects any device temperature >85°C for over 10 seconds.*

## System Profile

System Profile	
<b>MODEL</b>	Falcon-4010
<b>SERIAL NUMBER</b>	00000-6664133
<b>MAC ADDRESS</b>	DE:47:59:42:40:85
<b>FIRMWARE</b>	0.2.15-201130
<b>SYSTEM UP TIME</b>	19:57
<b>LAST LOGIN</b>	10.0.21.62 [ admin ]
<b>LAST LOGIN TIME</b>	1.75 hour(s) ago
<b>ONLINE USER</b>	3 user(s) are operating

The System Profile chart displays basic system information of the chassis being operated.

- Model:** chassis model name
- Serial number:** the serial number of the chassis
- Mac address:** mac address of the chassis
- Firmware:** current BMC firmware version
- System up time:** time since the system is powered-on
- Last Login:** The last user that logged in
- Online user:** The number of users currently on

## 7.2.2 Resource Management

The topology view shows the graph of hosts, devices, and PCIe switch. The list view lists all the devices and hosts in a table.

Under advanced mode, users can provision or re-provisioned the PCIe devices to connected hosts using topology view.

### Topology view

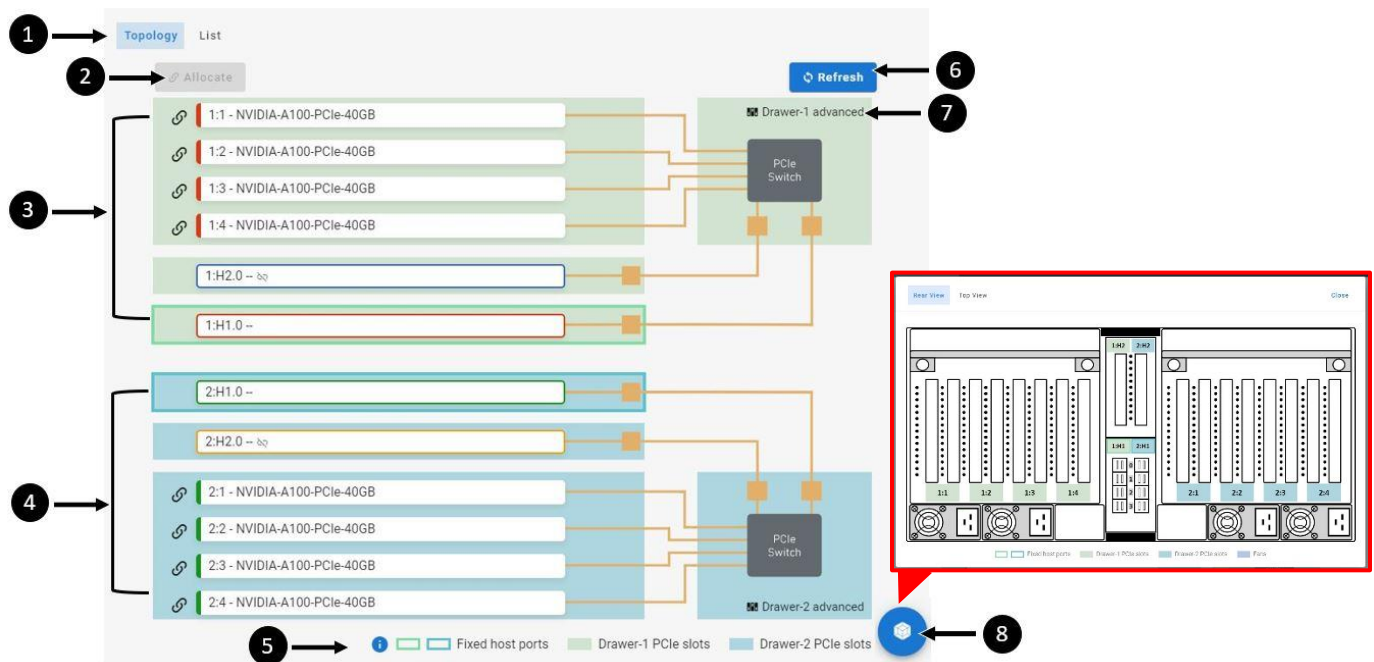

- 1. Display mode:** PCIe resources can be displayed in either the topology mode or the list mode.
- 2. Allocate:** This button is used when allocating resource to the hosts. See ***Device Allocation*** section for details.
- 3. Drawer 1 PCIe ports:** PCIe ports of drawer 1 are in green background.
- 4. Drawer 2 PCIe ports:** PCIe ports of drawer 2 are in blue background.
- 5. Legends:** Help users to clarify the components in the topology mode
- 6. Refresh:** Click to refresh the topology display
- 7. System mode:** Display the current system mode of the drawers.
- 8. Port label aid:** Click the icon, the chassis diagram with port labels will pop-up for aid.

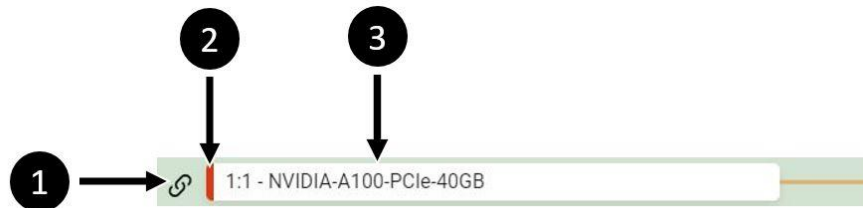

**Port Information:**

- 1. **Link icon:** This icon indicates that the device is assigned to a host already.
- 2. **Color tag:** Each host has a colored frame. This color tag indicates that the device is assigned to the host with the same color.

E.g.

*The device 1:1 is assigned to the host 1:H1 (color = red)*

- 3. **Port & Device:** Port number and the device name is displayed in the white box.

**List view**

Slot#	Assigned Host	Device Name	Type	UUID / Serial Number	Temp.C	Link Capability
1:1.0	-	NVIDIA-A100-PCIe-40GB	GPU	GPU-9ebae45a-494d-7956-7025-2bb8f5827d3c	34	G4x16/G4x16
1:2.0	-	NVIDIA-A100-PCIe-40GB	GPU	GPU-B7849aa5-D87c-8e43-1898-Fa506d1ba0eb	33	G4x16/G4x16
1:3.0	1:H1.0	NVIDIA-A100-PCIe-40GB	GPU	GPU-04851ec5-B538-7670-5ee0-4c4759816ab7	33	G4x16/G4x16
1:4.0	1:H1.0	NVIDIA-A100-PCIe-40GB	GPU	GPU-5317d527-1e87-73b1-11e7-018c851a28a3	33	G4x16/G4x16
2:1.0	2:H1.0	NVIDIA-A100-PCIe-40GB	GPU	GPU-C409b3b0-112a-31b9-7293-16732202481c	55	G4x16/G4x16
2:2.0	-	NVIDIA-A100-PCIe-40GB	GPU	GPU-41e8550d-89bc-09e7-D052-1177e36f49e9	63	G4x16/G4x16
2:3.0	-	NVIDIA-A100-PCIe-40GB	GPU	GPU-E0a3c56b-50fb-1c8f-50e6-1d9d03db703f	55	G4x16/G4x16
2:4.0	-	NVIDIA-A100-PCIe-40GB	GPU	GPU-Fa29e814-Cb33-59d8-21f6-908c2f11bb6b3	59	G4x4/G4x16

Slot#	Assigned Host	Device Name	Type	UUID / Serial Number	Temp.C	Link Capability
1:1.0	-	NVIDIA-A100-PCIe-40GB	GPU	GPU-9ebae45a-494d-7956-7025-2bb8f5827d3c	34	G4x16/G4x16

**NVIDIA**

Product Name : NVIDIA-A100-PCIe-40GB  
 Board Part No. : 900-21001-0000-000  
 Temperature : 34  
 Serial No. : 1323120034639  
 VBIOS Version : 92.00.25.00.08  
 Image Version : 1001.0200.00.04

Vendor ID : 10de  
 Sub System ID : 145f  
 Device ID : 20f1  
 UUID : GPU-9ebae45a-494d-7956-7025-2bb8f5827d3c  
 Fan Speed : -  
 Build Date : 2020/07/30

*\*Each roll contains the information of a PCIe slot in use, the PCIe slots that are empty will not be listed.*

- 1. **Slot#:** This column shows all the PCIe slots with device installed.
- 2. **Assigned host:** This column shows the hosts that the devices are currently assigned to.
- 3. **Device name:** This column shows the device name
- 4. **Type:** This column shows the device type. (GPU, NVMe SSD, or NIC)
- 5. **UUID/Serial number:** This column shows the UUID and serial number of the devices
- 6. **Temperature:** This column shows the temperature of the devices
- 7. **Link capability:** This column shows the link capability of the devices [Device link capability] / [Slot link capability].

- 8. **Device details:** Click on the drop-down arrow to see detailed information of the selected device.
- 9. **Port label aid:** Click the icon, the chassis diagram with port labels will pop-up for aid.

*\*The data is read from PCIe devices directly, only available if the device provides the out-band information.*

## Device Allocation

This feature is only enabled in **Advanced mode**.

Go to **Resource Management** page  
(Use Topology mode)

1. Select the target host
2. Check the box beside the vacant device
3. Click “Allocate” to assign the device to the host

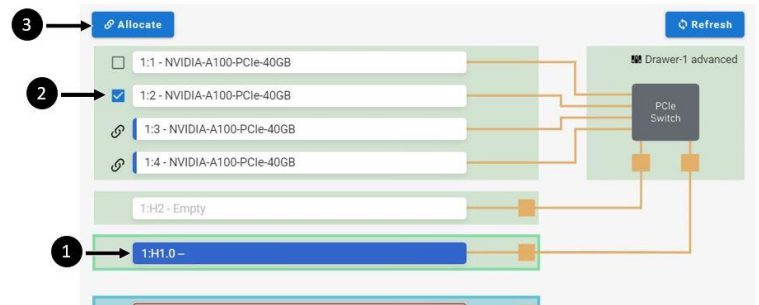

If multiple PCIe devices should be provisioned to one connected host, users can also select multiple devices at one time then allocate to one connected host.

The confirmation message will pop-up to ask users for confirmation.  
Click “Yes” to confirm. Click “OK” to finish the provisioning processes.

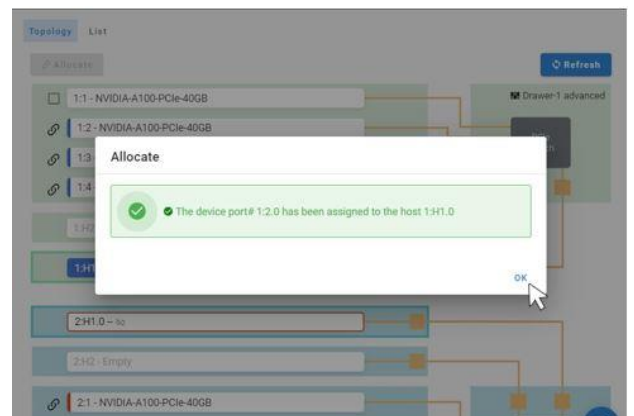
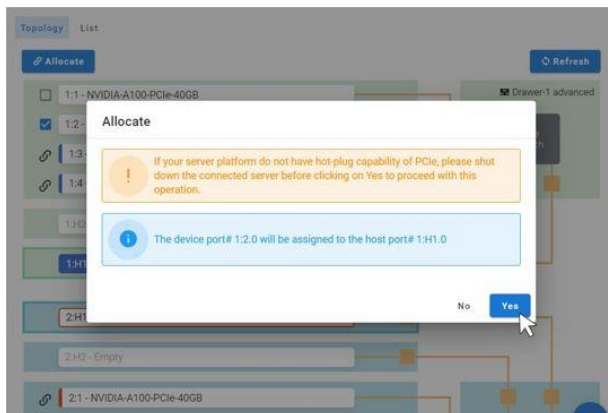

After you have assigned the device to a host, the **link icon** and the **color tag** should appear.

e.g.





## Release Device from host

This feature is only enabled in **Advanced mode**.

Go to **Resource Management** page  
(Use Topology mode)

1. click the link icon next to the target device

You can only deallocate one device at a time with this method.

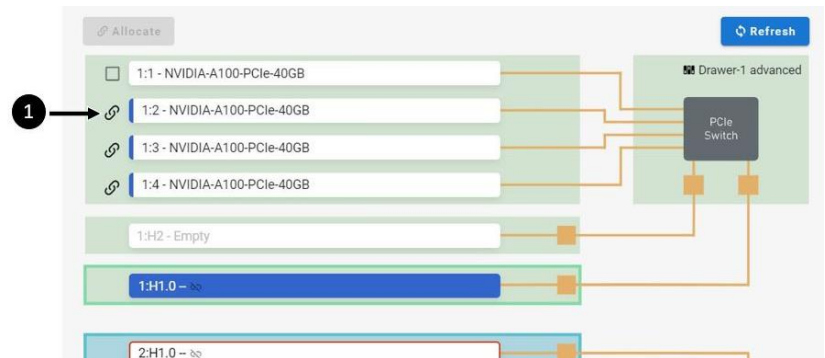

The confirmation message will pop-up to ask users for confirmation.  
Click “Yes” to confirm. Click “OK” to finish the provisioning processes.

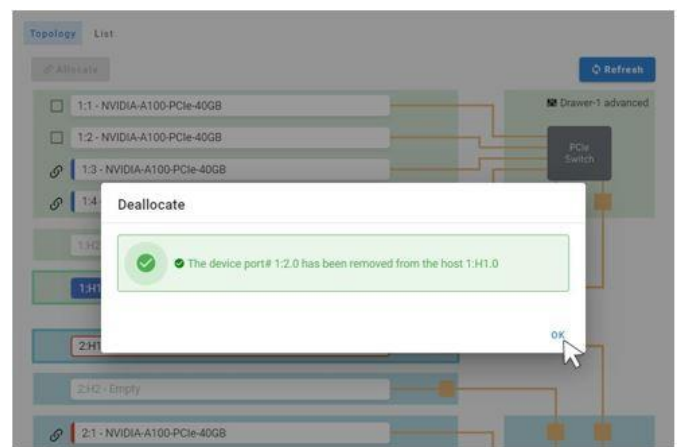
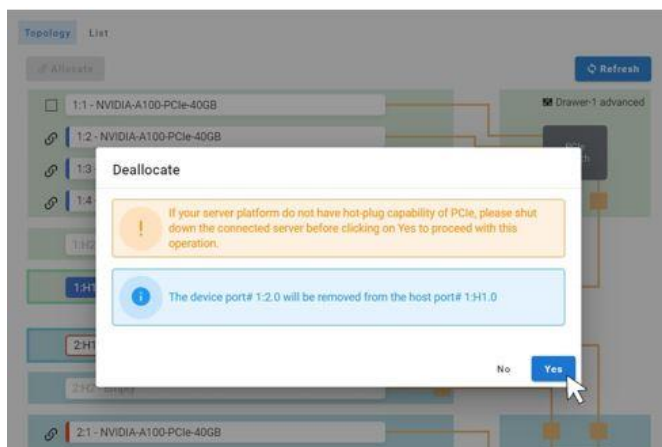

After you have assigned the device to a host, the **link icon** and the **color tag** should disappear.  
The **check box** should appear.

e.g.





## 7.2.3 Port Configuration

Falcon 4010 provides user defined PCIe port configurations. All PCIe ports are default to 16 lanes (PCIe 4.0). The lanes can be configured into 2x8 lanes or 4x 4lanes depending on the custom requirements.

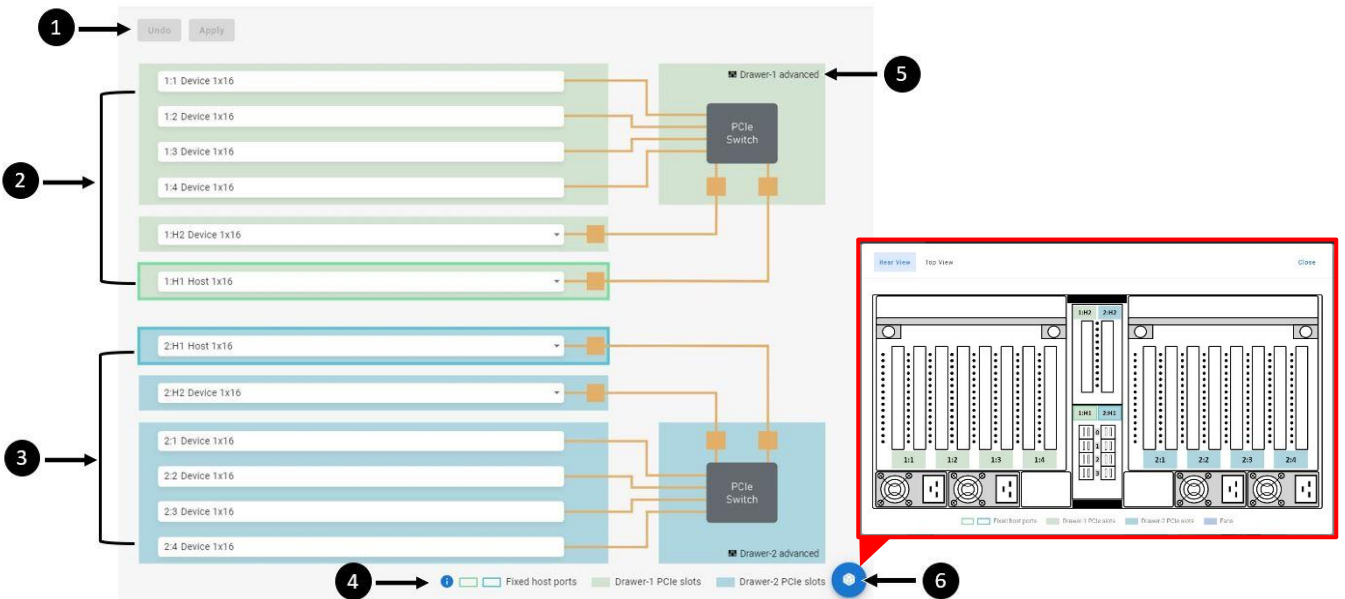

1. **Undo and Apply:** Undo or Apply configuration settings. See **Configure Ports** section for details.
2. **Drawer 1 PCIe Ports:** PCIe ports of drawer 1 are in green background.
3. **Drawer 2 PCIe Ports:** PCIe ports of drawer 2 are in blue background.
4. **Legends:** Help users to clarify the components in the topology mode
5. **System mode:** Display the current system mode of the drawers.
6. **Port label aid:** Click the icon, the chassis diagram with port labels will pop-up for aid.

### Configure Ports

This feature is only enabled in **Advanced mode**.

Go to **Port Configuration** page.

There are 4 configurable ports:

**1:H1, 2:H1, 1:H2, and 2:H2**

#### Note

1:H1 and 2:H1 are fixed host ports, users can only control the bifurcation setting.

1:H2 and 2:H2 can be configured into device or host port, bifurcation setting is only available for host mode.

(continue next page)

1. Click the drop-down icon of the PCIe port to be configured and select the desired configuration.
2. Click “Apply” to apply the configuration, click “Undo” to discard the configuration

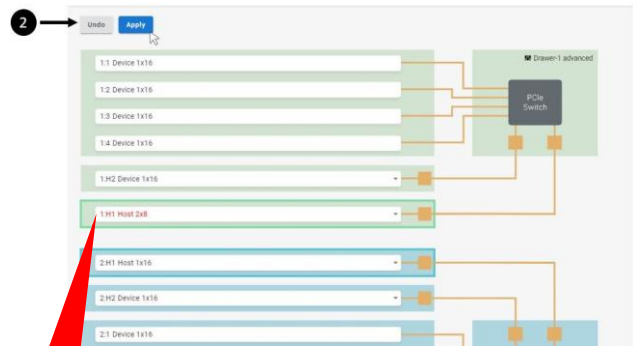
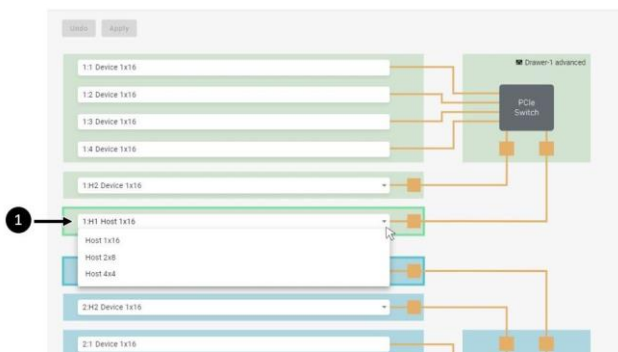

*Red text indicates that the configuration is not applied yet.*

The confirmation message will pop-up to ask users for confirmation. Click “Yes” to confirm. Click “OK” to finish the configuration processes.

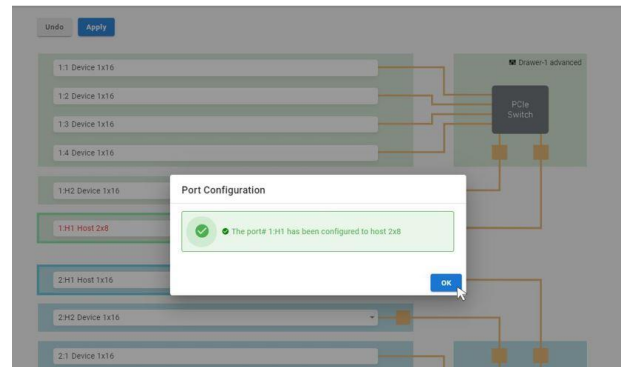
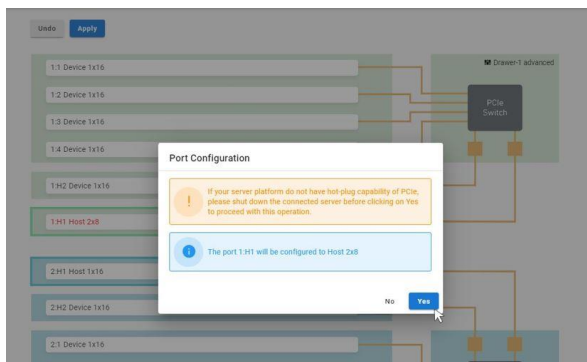

After you finished the configuration, your new configuration will be displayed, and the text should turn **Black**.

e.g.



**Please reboot Falcon 4010 (or the drawer) for the new configuration to take effect**

## 7.2.4 Monitor

In the Monitor page, users can see the real-time **traffic**, **link speed**, and the **error count** of each PCIe port.

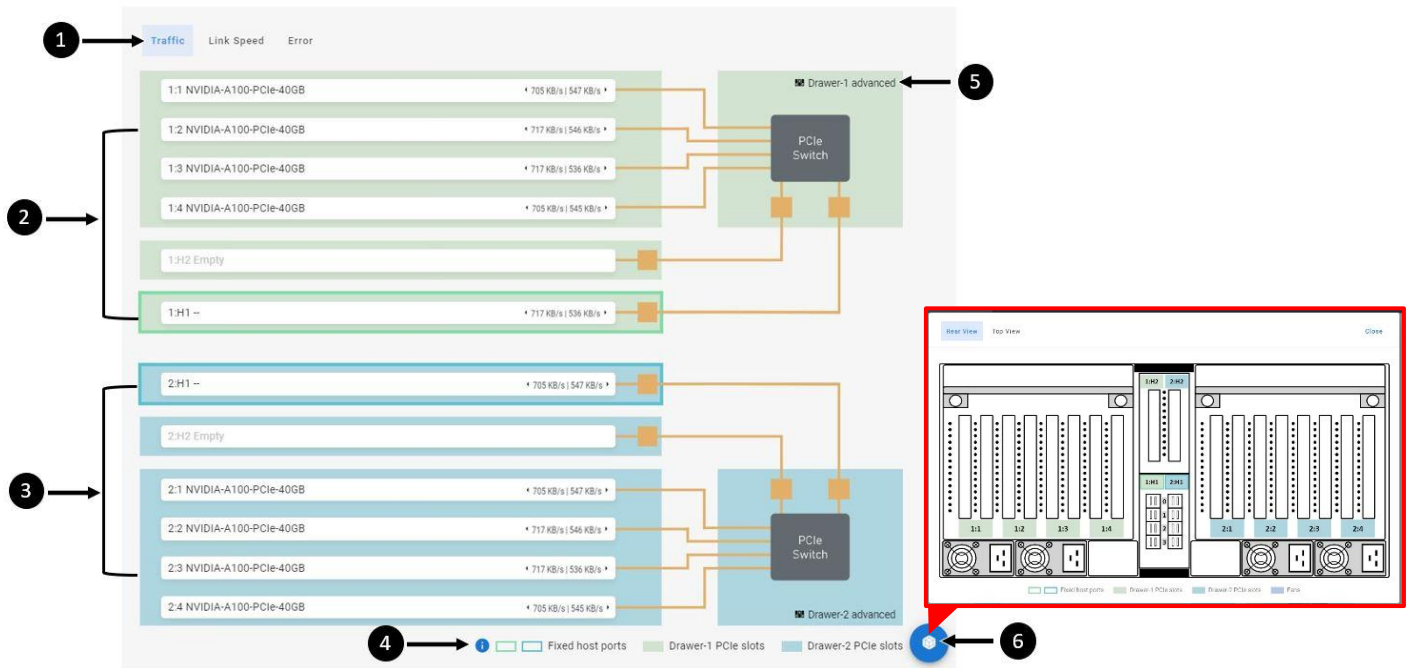

1. **Sub-menu:** Select the monitor information you would like to see.
2. **Drawer 1 PCIe ports:** PCIe ports of drawer 1 are in green background.
3. **Drawer 2 PCIe ports:** PCIe ports of drawer 2 are in blue background.
4. **Legends:** Help users to clarify the components in the topology mode
5. **System mode:** Display the current system mode of the drawers.
6. **Port label aid:** Click the icon, the chassis diagram with port labels will pop-up for aid.

### Traffic

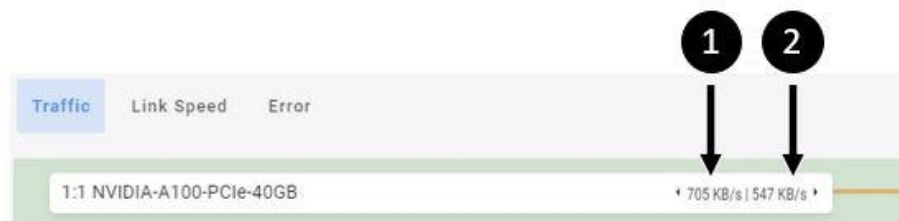

When select Traffic, the traffic information will show up on the right side of every white box (port)

1. **Egress Traffic:** PCIe switch to device traffics
2. **Ingress Traffic:** Device to PCIe switch traffics

## Link Speed



When select Link Speed, the link speed information will show up on the right side of every white box (port).

Display format

**[PCIe generation] x[PCIe lanes].**

e.g.

Nvidia A100 PCIe is a PCIe Gen4 x16lane device, under normal condition, the link speed should be displayed as **Gen4 x16**

1. **Current link speed:** The current link speed of the device installed on the PCIe port.
2. **Maximum link speed:** The maximum link speed of the PCIe port

Note:

Max link speed should always be Gen4 x16, the current link speed is depending on the device installed.

## Error

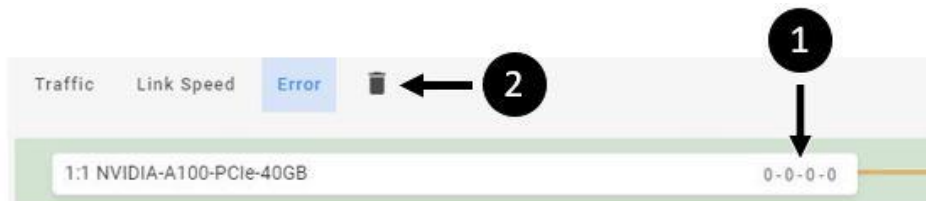

When select Error, the PCIe error count will show up on the right side of every white box (port).

Display format

**[Bad DLLP] – [Bad TLP] – [Port RX Error] – [Recovery Diag. Error]**

e.g.

0-0-0-2 indicates that there are two Recovery Diag. Error count.

1. **Error counts:** displays the number of each error type.
2. **Clear errors:** Click the icon to reset all error counts. (back to 0-0-0-0)

## 7.2.5 System Health

The System Health page provides consolidated health information of the chassis.

Including **drawer and device temperatures, chassis temperature, power consumptions, and fan speeds.**

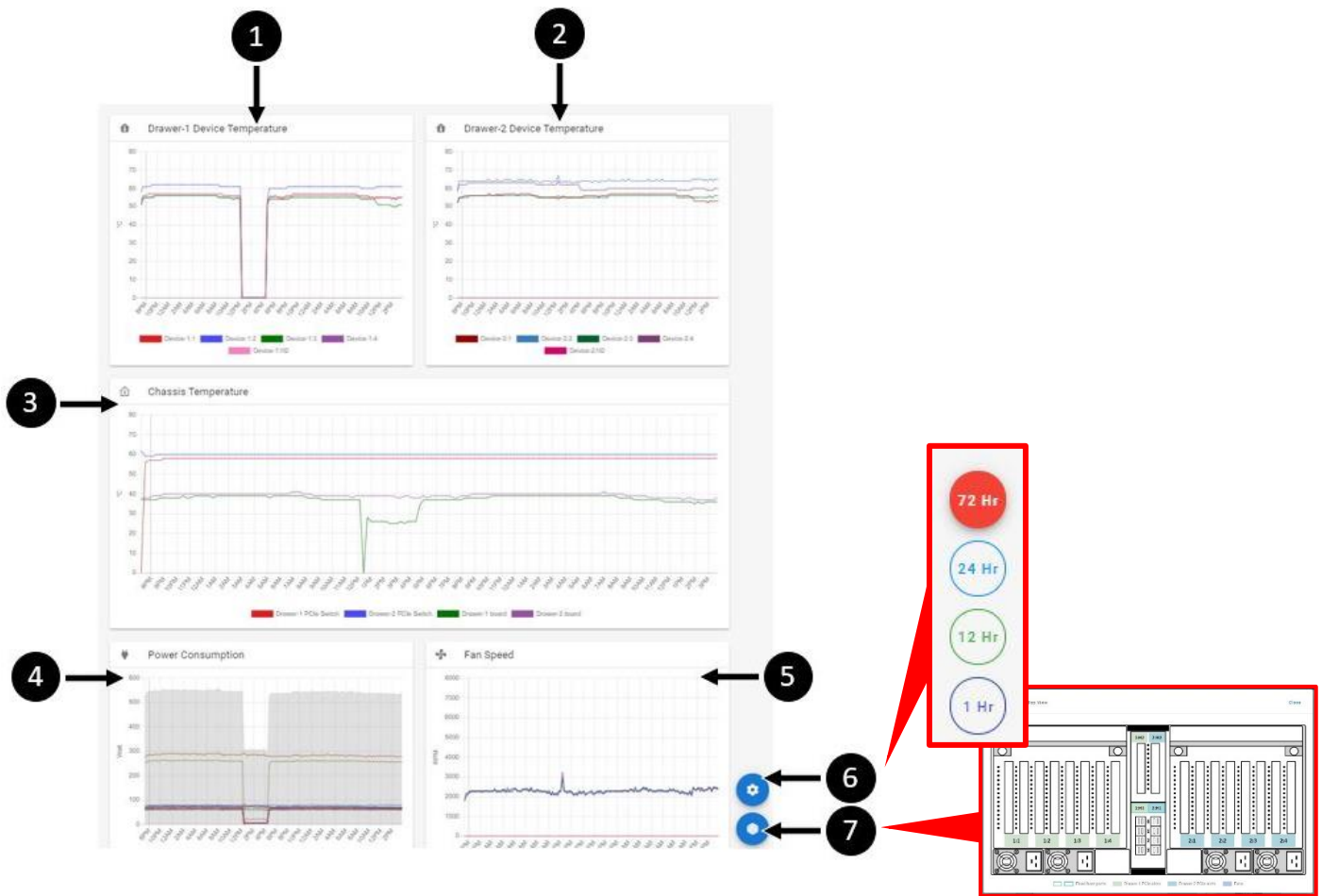

- 1. Drawer 1 device temperature graph:** see **Device temperature graph** section for details.
- 2. Drawer 2 device temperature graph:** see **Device temperature graph** section for details.
- 3. Chassis temperature graph:** see **Chassis temperature graph** section for details.
- 4. Power consumption graph:** see **Power consumption graph** section for details.
- 5. Fan speed graph:** see **Fan speed graph** section for details.
- 6. Port label aid:** Click the icon, the chassis diagram with port labels will pop-up for aid. (Select "Top view" for fan numbers)
- 7. Select period:** Click the icon, select the time interval for all the graphs.

## Device temperature graph

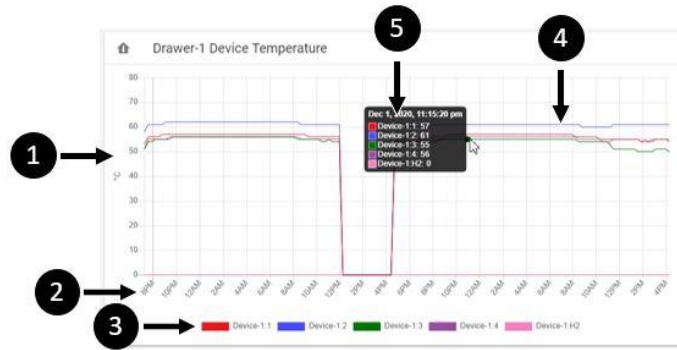

1. **Temperature:** Temperature scale in degree Celsius
2. **Time:** Time scale in hours
3. **Devices:** List of devices in the drawer, each given a color tag  
e.g. Device 1:2 in the above image is given a **blue** tag
4. **Temperature curve:** Temperature curves of all devices in the drawer, colors are corresponding to the devices  
e.g. The **blue** curve represents the temperature of device 1:2
5. **Instantaneous temp.:** Move the cursor over any point on the graph, the temperature of all devices at the specific time will be shown in the black menu

## Chassis temperature graph

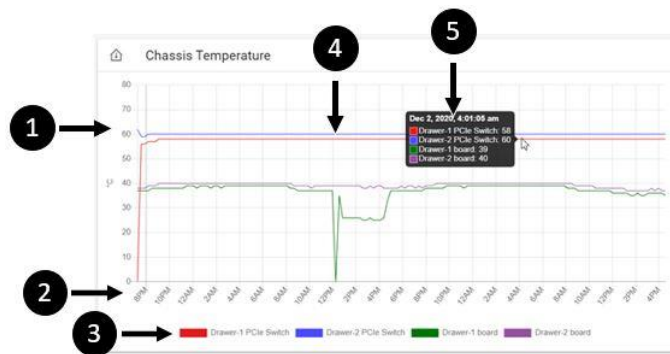

1. **Temperature:** Temperature scale in degree Celsius
2. **Time:** Time scale in hours
3. **Devices:** List of chassis component, each given a color tag  
e.g. Drawer 2 PCIe switch is given a **blue** tag
4. **Temperature curve:** Temperature curves of all devices in the drawer, colors are corresponding to the devices  
e.g. The **blue** curve represents the temperature of Drawer 2 PCIe switch
5. **Instantaneous temp.:** Move the cursor over any point on the graph, the temperature of all components at the specific time will be shown in the black menu

## Power consumption graph

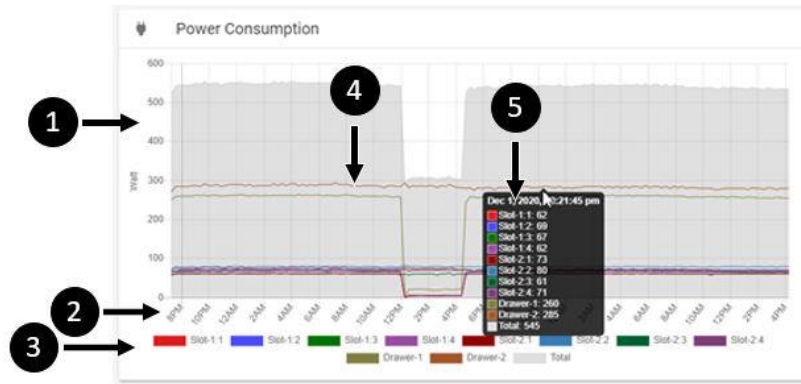

- Power consumption:** Power consumption scale in degree Watts
- Time:** Time scale in hours
- Devices:** List of devices/drawers, each given a color tag  
e.g. *Drawer 2 is given a brown tag*
- Temperature curve:** Temperature curves of all devices in the drawer, colors are corresponding to the devices  
e.g. *The brown curve represents the power consumption of Drawer 2*
- Instantaneous temp.:** Move the cursor over any point on the graph, the power consumption of all components at the specific time will be shown in the black menu

Note:

The gray area represents the overall power consumption. (sum of all devices)

## Fan speed graph

For fan numbers refer to **Port label aid > Top view**

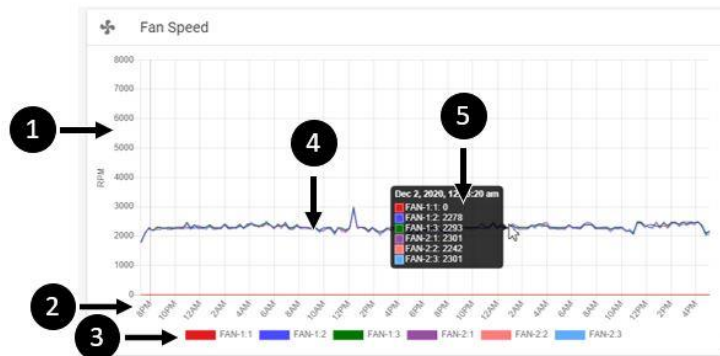

- Fan speed:** fan speed scale in RPM
- Time:** Time scale in hours
- Devices:** List of fans, each given a color tag  
e.g. *Fan 1:2 is given a blue tag*
- Temperature curve:** Temperature curves of all devices in the drawer, colors are corresponding to the devices  
e.g. *The blue curve represents the speed of Fan 1:2*
- Instantaneous temp.:** Move the cursor over any point on the graph, the temperature of all components at the specific time will be shown in the black menu



## 7.2.6 Chassis

In the Chassis page, users can control the power of chassis UID, and the power of the GPU drawers separately.

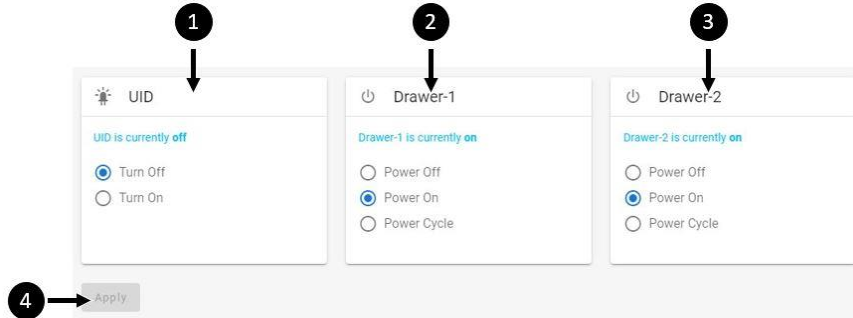

1. **UID power:** select operations to Falcon 4010 UID
2. **Drawer 1 power:** select operations to drawer 1
3. **Drawer 2 power:** select operations to drawer 2
4. **Apply:** the selected operations will start process after clicking “Apply”

Note.

The **light-blue** text shows the current power status of the component.

After clicking “Apply”, the confirmation message will pop-up.  
Click “Yes” to proceed, click “Close” when the process end.

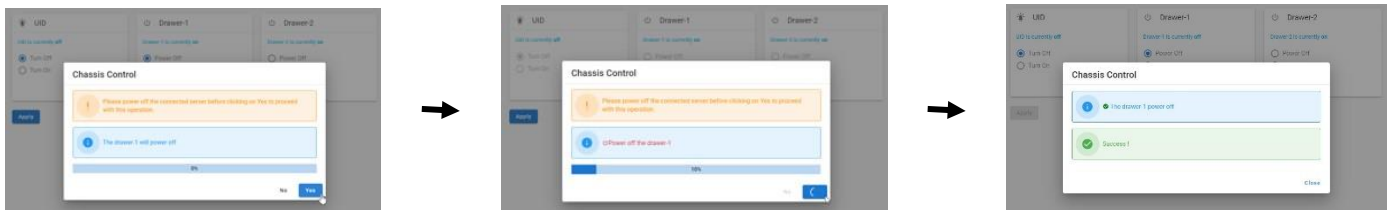



## 7.2.7 Maintenance

View the current firmware information and update firmware from the **Maintenance** page

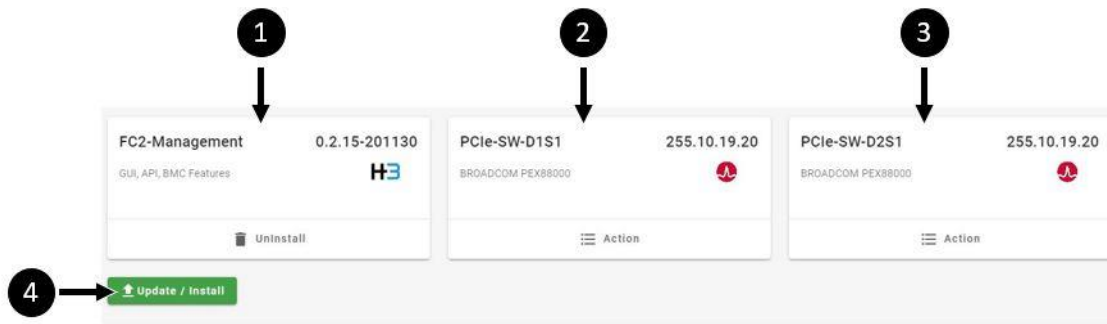

1. BMC firmware information
2. Drawer 1 PCIe switch firmware information
3. Drawer 2 PCIe switch firmware information
4. Upload/Install (see Firmware update section for details)

## Firmware update

You will have to download the latest firmware files from H3 Platform official website (<https://www.h3platform.com/knowledge-base/document>)

Go to Knowledge Base → Download

**Product type:** Composable GPU Chassis  
**Model type:** Falcon 4010  
**Download item:** Firmware

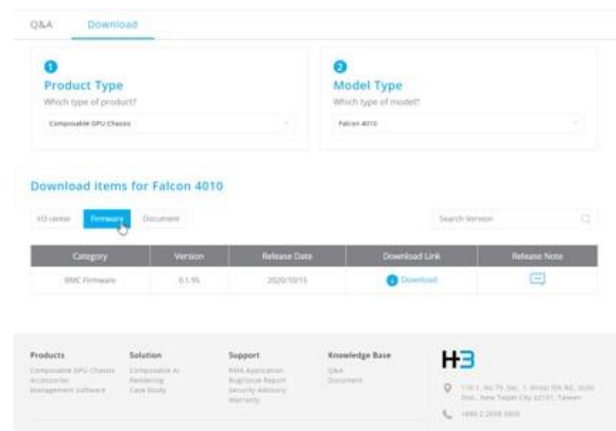
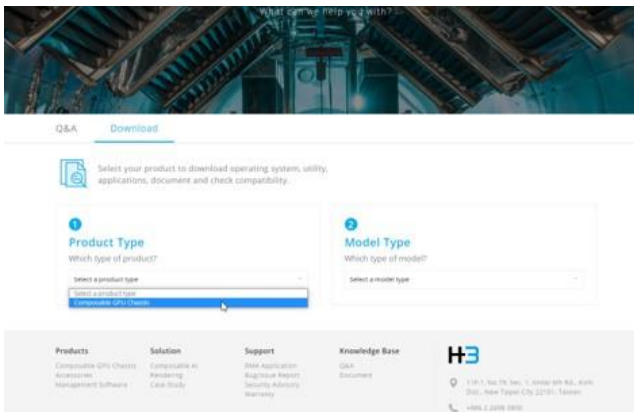

Download the firmware file to your device (i.e. your PC)

(continue next page)

Go to Falcon 4010 GUI → Maintenance page

Click “Upload/Install”

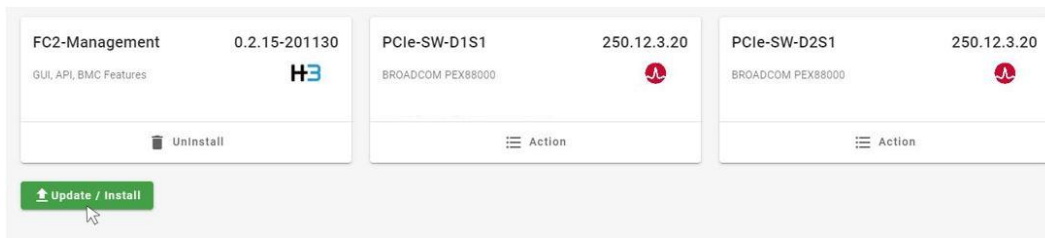

Upload the firmware .img file. The confirmation message will pop-up, click “Yes” to proceed.

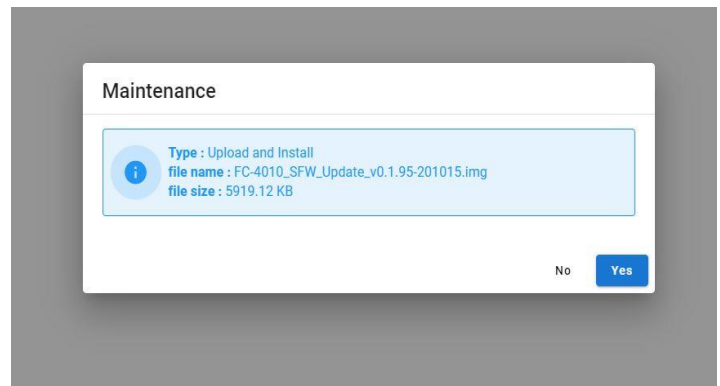
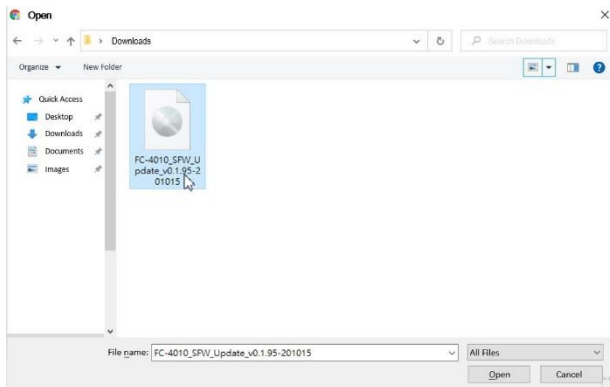

When the update completes, the notification message will pop-up, click “Close” to end

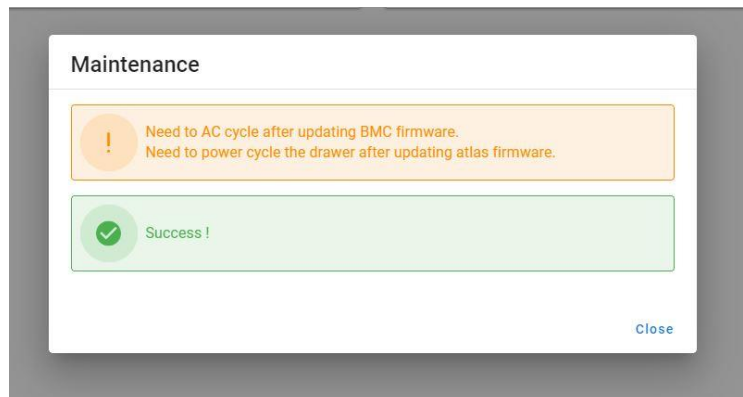

**Now reboot Falcon 4010, the new firmware will be installed.**

Note:

The system will automatically detect which firmware file is uploaded (BMC, PCIe switch 1, or PCIe switch 2)

Firmware for PCIe switch 1 and 2 are not the same.

## 7.2.8 Event Logs

In the Event Logs page, users will find consolidated logs. The logs are filtered by log levels, users can find specific logs by levels or using the search bar.

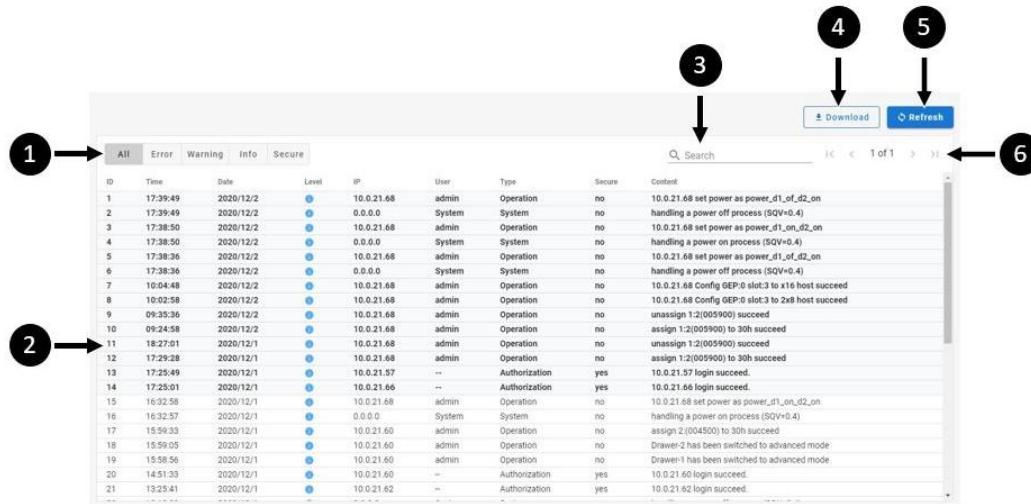

1. **Select log types:** Sort logs by levels
2. **Logs:** Actual logs (new → old, ID number ascending)
3. **Search bar:** type in to search for specific log(s)
4. **Download logs:** Click to download all logs (.csv format)
5. **Refresh logs:** Click to refresh the logs displayed
6. **Select page:** go to next or previous pages of logs

Note:

The logs in **bold** text are unread logs

The **security logs** refer to all account activities related logs

log-in & outs, wrong passwords, create accounts, remove accounts, modify accounts...etc

## 7.2.9 Setting

In Setting page, users can modify all the system settings, manage accounts and licenses. Functions including **time setting**, **network setting**, **user management**, **ELK configuration**, and **license management**.

### Time setting

Find your time setting information or modify time settings from the **Time Settings** page.

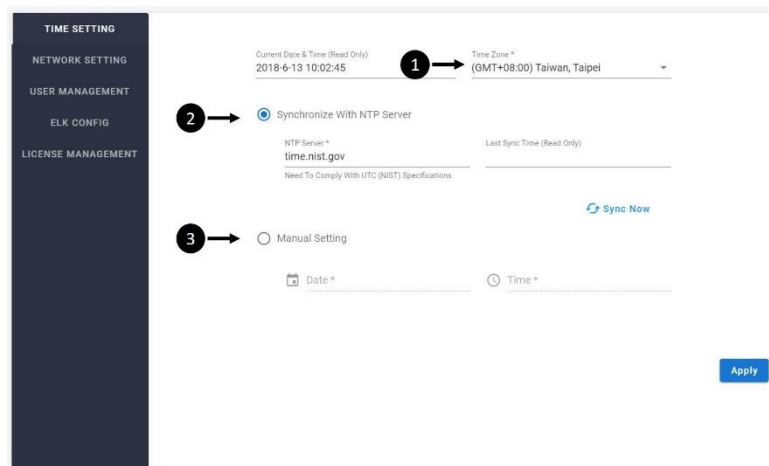

#### 1. Time zone:

Set/modify your time zone

#### 2. Synchronize with NTP server:

Sync system time with a NTP server or modify sync targets

1. Type in the NTP server IP address
2. Click “Sync Now”

#### 3. Manual setting:

Set/modify system time manually

1. Set a “Date”
2. Set a “Time”
3. Click “Apply” to update any time setting changes.

## Network setting

Find your network setting information or modify network settings from the **Network Settings** page.

The screenshot shows a web interface for network settings. On the left is a dark sidebar with menu items: TIME SETTING, NETWORK SETTING (highlighted), USER MANAGEMENT, ELK CONFIG, and LICENSE MANAGEMENT. The main content area is titled 'TCP / IP setting' and 'DNS Setting'. Under 'TCP / IP setting', there are two radio buttons: 'Obtain IP address automatically (DHCP)' (unselected) and 'Use the following IP address (Static IP)' (selected). Below are three input fields: 'IP Address \*' with '10.0.24.54', 'Subnet Mask \*' with '255.255.0.0', and 'Default Gateway \*' with '10.0.21.1'. Under 'DNS Setting', there are two radio buttons: 'Obtain DNS server address automatically' (unselected) and 'Use the following DNS server address' (selected). Below is one input field: 'DNS server \*' with '8.8.8.8'. At the bottom right, there is a blue 'Apply' button. Three numbered callouts (1, 2, 3) with arrows point to the 'Use the following IP address (Static IP)' radio button, the 'DNS server \*' input field, and the 'Apply' button respectively.

### 1. TCP/IP settings:

- Obtain IP address automatically
- Use a static IP address

Users must fill in the **IP address**, **Subnet Mask**, and **Default Gateway** fields for this option.

### 2. DNS settings:

- Obtain DNS server address automatically
- Use the following DNS server address

Users must fill in the **DNS Server** address for this option.

### 3. Apply

Click “Apply” to update any network setting changes.

### Note:

After you modify the network settings, you will have to click apply for the new setting to take effect.

## User management

Manage user accounts, change user passwords, create/delete user accounts from the **User Management** page.

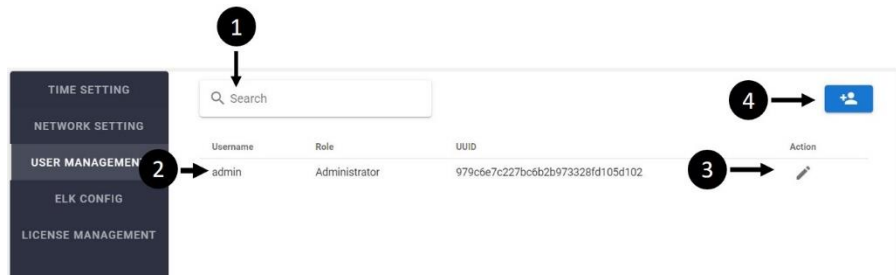

### 1. Search bar:

Search for specific user information

### 2. User details:

Each roll contains details of the accounts, including **username**, **role\***, and **UUID**.

### 3. Edit user accounts:

Click the edit icon to change password for the account

#### Change password:

1. Fill in the new password
2. Confirm the new password
3. Click "Yes" to proceed

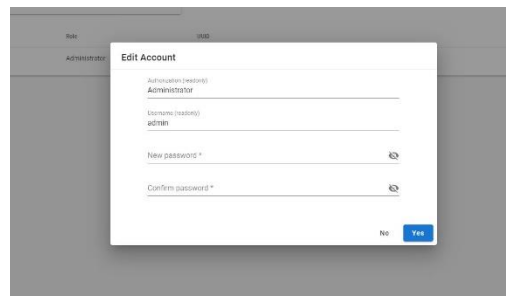

After you change the password, the notification message will pop-up, click close.

### 4. Create new accounts:

Click the icon to create new accounts

1. Select user role
2. Fill in the username
3. Fill in the password
4. Confirm the password
5. Click "Yes" to create

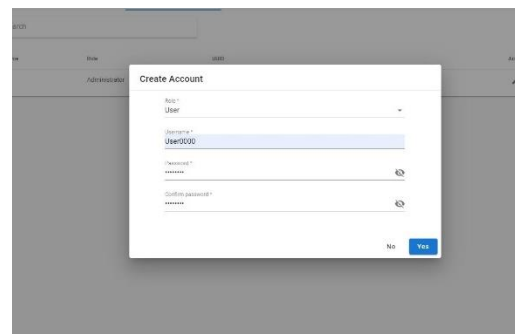

After you create an account, the notification message will pop-up, click close.

## Delete user accounts



Click the delete icon to delete the account.

The confirmation message will pop-up, click “Yes” to proceed. Click “Close” when finished.

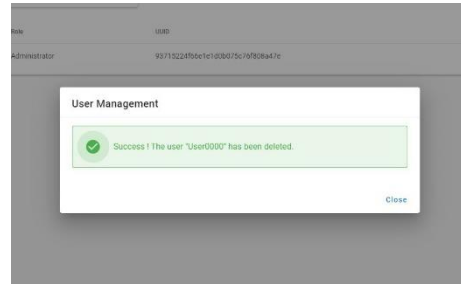
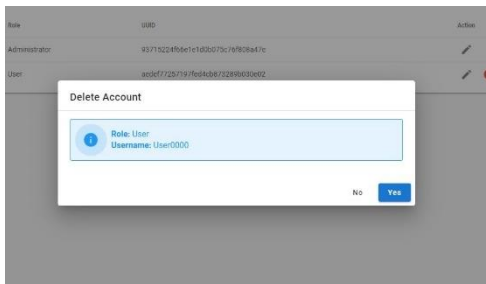

## User roles and Authorities

	Administrator	User_Admin	User	Guest
Read PCIe Resource	O	O	O	O
Read Chassis Info	O	O	O	O
Read System Logs	O	O	O	X
Manage PCIe Resource	O	O	O	X
Change Password	O	O	O	X
Read System Settings	O	O	X	X
Read Maintenance Info	O	O	X	X
Read Security Logs	O	O	X	X
User Account Management	O	O	X	X
Modify System Setting	O	X	X	X
Maintenance Operation	O	X	X	X

## ELK configuration

Find ELK server information or set up ELK server for log management from the **ELK Config.** page.

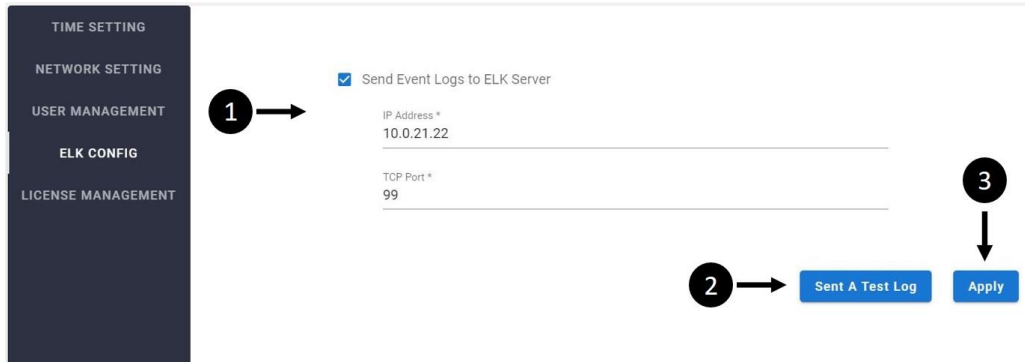

### 1. Set up ELK server:

1. Check the box to enable ELK server setting
2. Fill in the ELK server IP address
3. Fill in the TCP port

### 2. Send test log:

Send a test log to the ELK server to check the link.

### 3. Apply:

Click "Apply" to update any ELK server settings

Note:

After you modify the ELK configuration, you will have to click apply for the new setting to take effect.

## License management

Find your license information, activate your premium license key, or switch system modes from the **License Management** page.

### Software License Details:

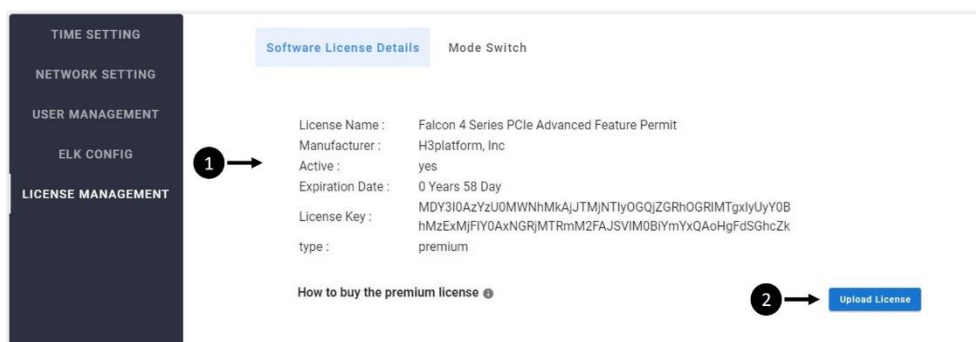

### 1. License information:

Display all information about your current license



## 2. Upload License

Activate your premium license keys here

1. Key in the license key
2. Click “Apply” to activate

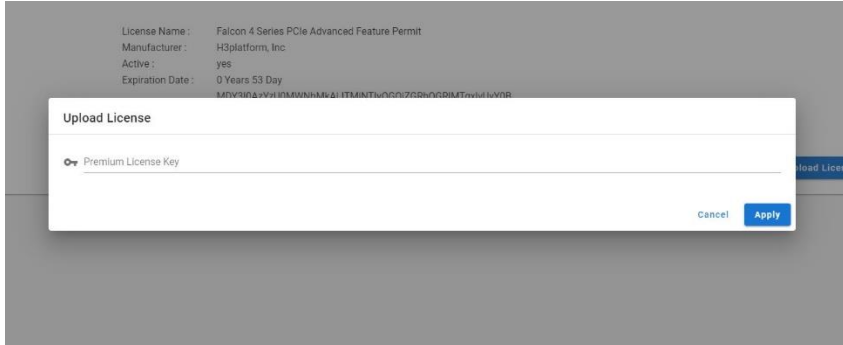

After you activate the license key, the notification message will pop-up, click “close” to end.

## Mode switch

*Please make sure you have powered-off the connected server before switching modes.*

1. Select the desired mode switch operation
2. Click “Apply”

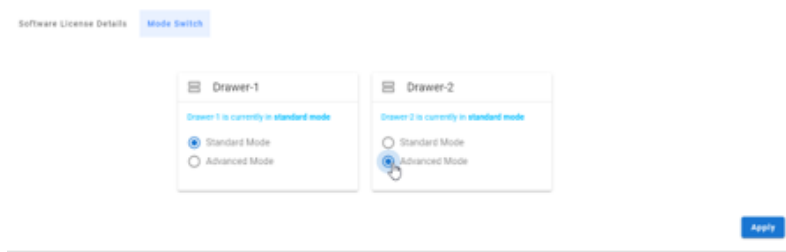

The confirmation message will pop-up, click “Yes” to proceed.

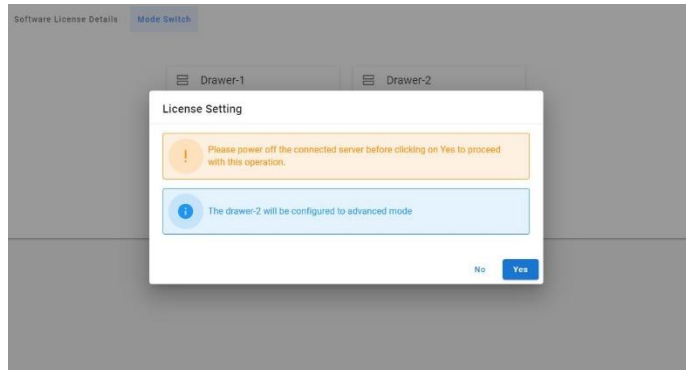

After you activate the license key, the notification message will pop-up, click “close” to end.

# 8. Parts Replacement

If any of your fans or PSU is out of order, you can order parts from H3 Platform directly. Please visit <https://www.h3platform.com/> for details.

## 8.1 Fans

Please use the suitable fans for replacement, damages caused by incompatible fan installation are not Warranted. (see Hardware specification for details)

Remove the top-front cover to replace fans.

The fans can be hot plugged. User Simply remove the fan that is out of order.

**Fan number reference:**

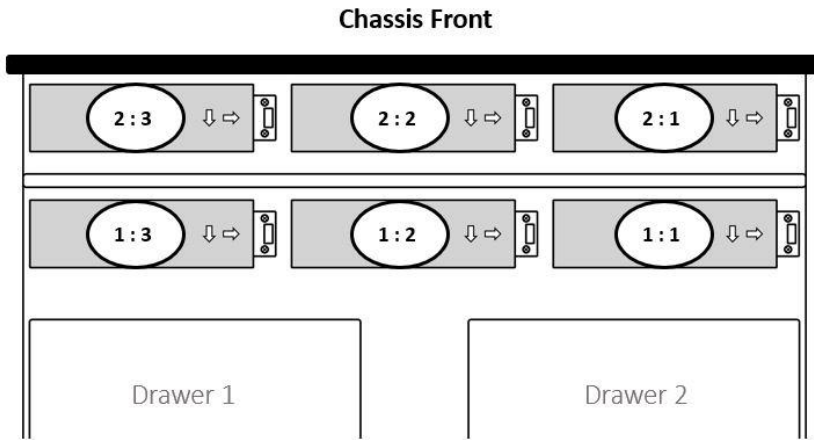

## 8.2 Power Supply Units

Please use the suitable power supply units for replacement, damages caused by incompatible power supply units are not warranted.

**Power supply unit reference:**

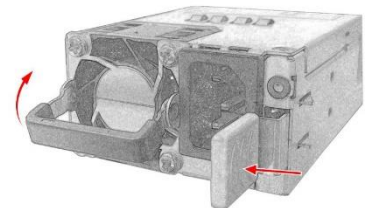
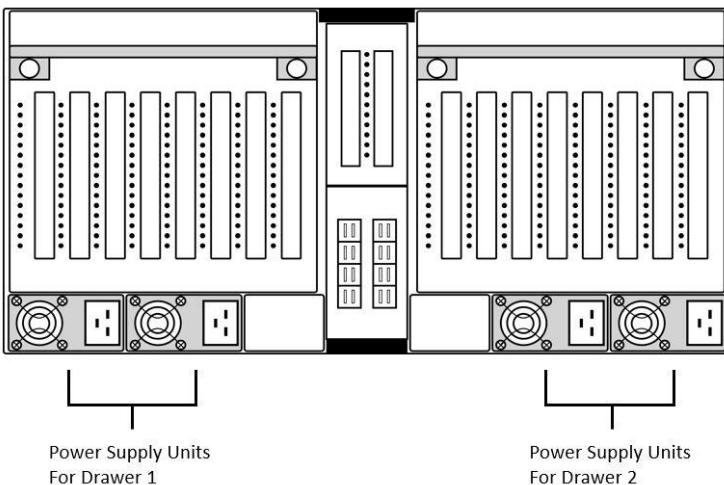

1. Lift the handle and press the release button
2. Pull out the PSU

## 9. LCD

Users can control the chassis using the LCD module on the chassis.

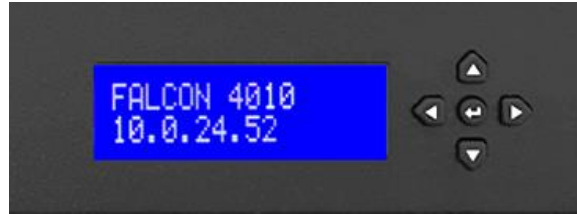

### 9.1 Operation

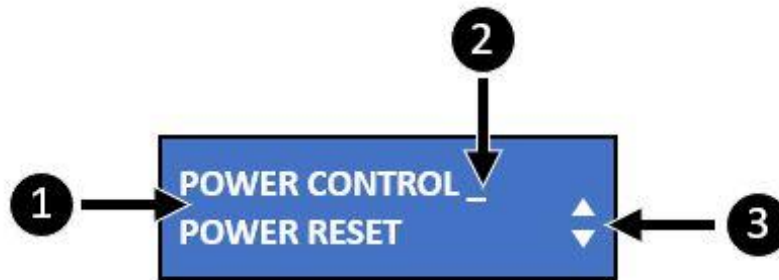

**1. The functions:**

List of functions accessible from the LCD module

**2. The cursor:**

Indicating that you are on the specific function (selected), press → button to enter the sub-menu.

**3. The scroll bar:**

Indicating that there are more functions at the same level, press ↑ and ↓ to see them.

## 9.2 Menus

### 9.2.1 Main menu

Press → button to enter the menu selection. Use the ↑ and ↓ button to scroll up and down the list.

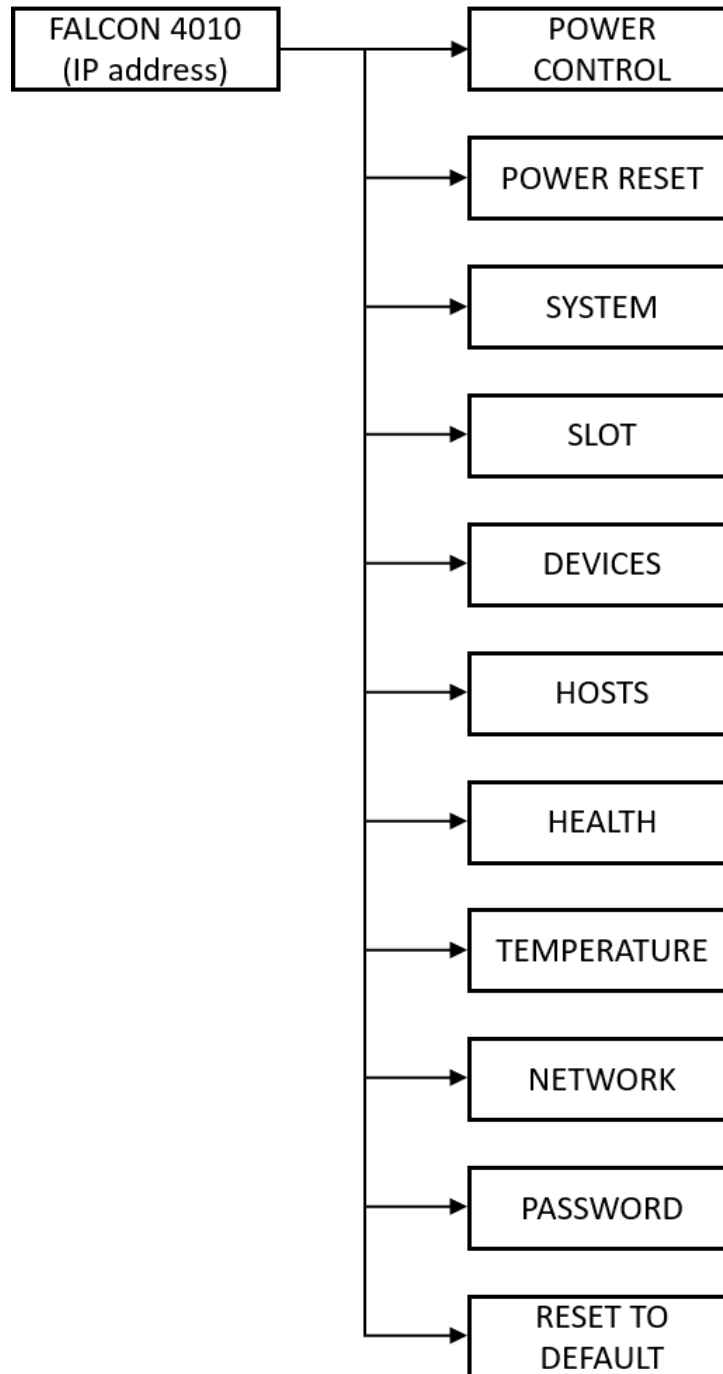

## 9.2.2 Power control

Users can turn drawers on/off from Power control.

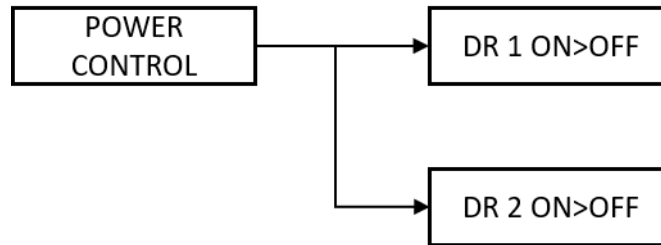

1. Select a drawer, press  $\leftarrow$  to proceed
2. Select "Yes" to confirm, select "No" to cancel



## 9.2.3 Power reset

Users can run drawer power-cycles.

\*power reset will **turn off then turn on** the drawers, different from the power control function.

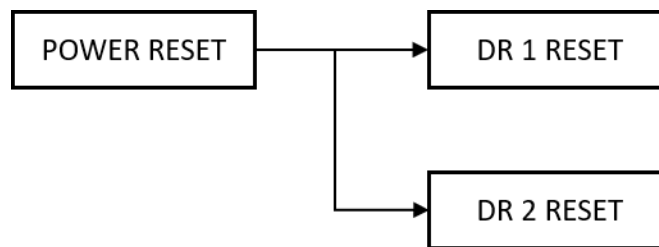

1. Select a drawer, press  $\leftarrow$  to proceed
2. Select "Yes" to confirm, select "No" to cancel



## 9.2.4 System

Users can view system information from System.

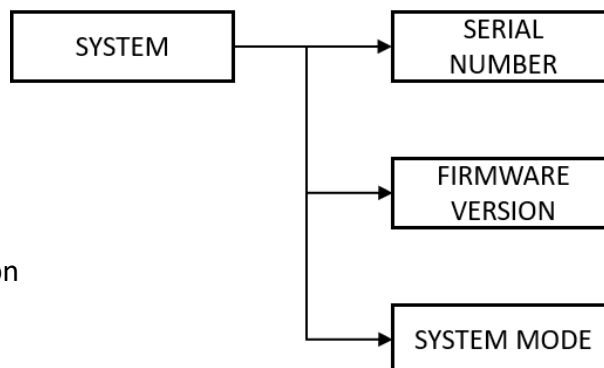

S/N = Serial number

FW = BMC firmware version

## 9.2.5 Slot

Users can view the link speed, availability of every device port, and the number of host server attached to every host ports

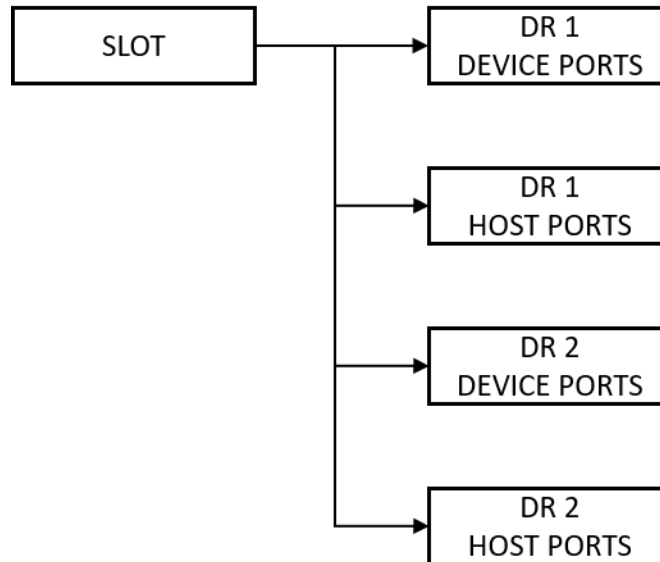

Device port from 1:1 ~ 1:4 and 2:1 ~ 2:4

Host Port from 1:H1 ~ 1:H2 and 2:H1 ~ 2:H2

### Device port info display format:

1:1	G4x16 / AVL	▲
1:2	G4x16 / ATT	▼

[drawer #]:[slot#] [PCIe generation]x[Lanes] / [Status]

AVL= Device available

ATT= Device is attached to a host

MTY= No device installed

### Host port info display format:

1:H1	1 Host	▲
1:H2	1 Host	▼

[drawer#]:[host#] [#of host machines attached]

## 9.2.6 Devices

Users can view port traffics, device name, device temperature, and error count.

\*Only the ports with devices installed will show.

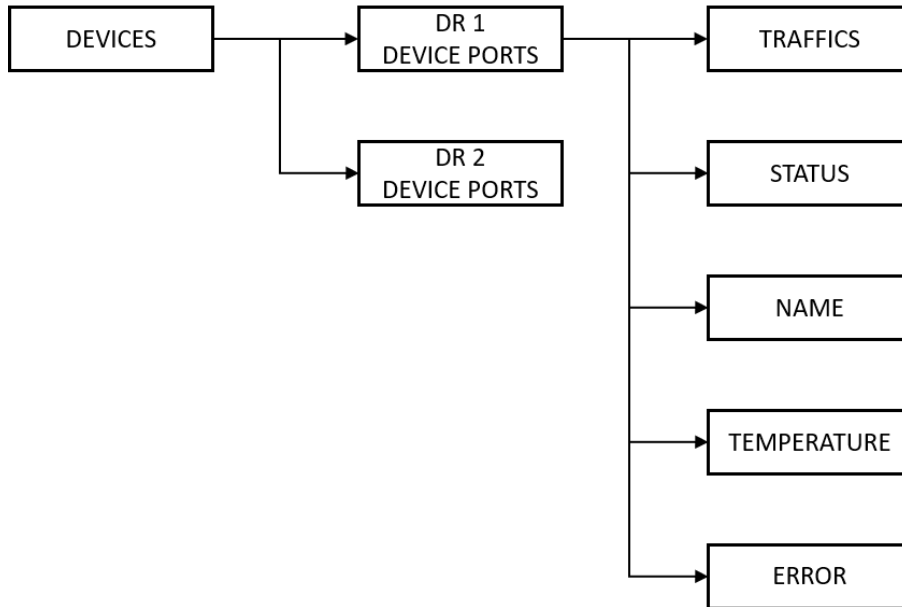

Device port from 1:1 ~ 1:4 and 2:1 ~ 2:4

Tx= PCIe switch to device traffic

Rx= Device to PCIe switch traffic

ERR= error counts [Bad DLLP] – [Bad TLP] – [Port RX Error] – [Recovery Diag. Error]

E.g.

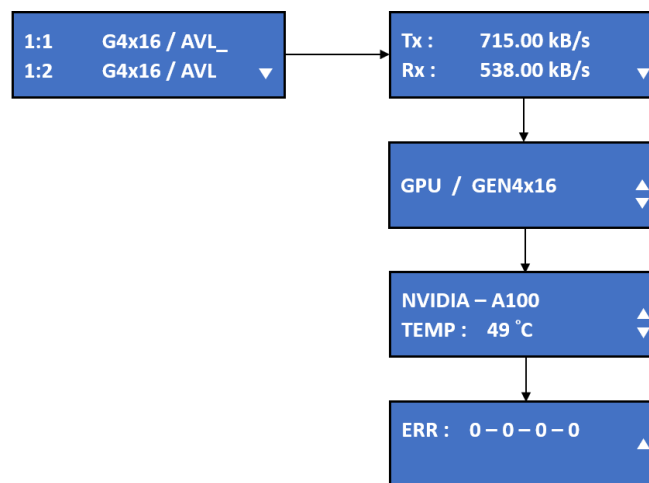

Device 1:1 is a NVIDIA-A100 GPU, PCIe gen4 x16, current temperature is 49°C, no error count.

## 9.2.7 Hosts

Users can see whether the host port connects to the host server or not. If it's linked, users can get further information such as which device is allocated to the host.

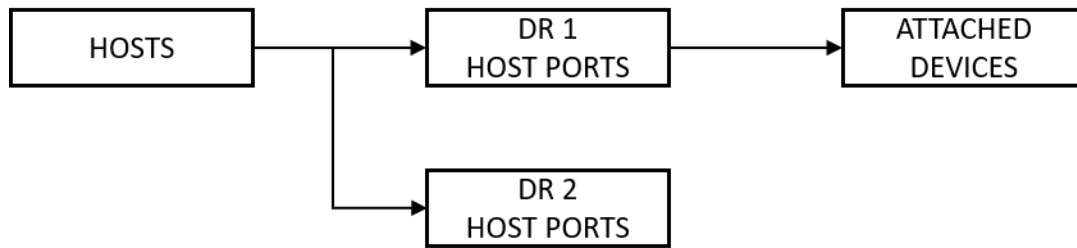

**Host port display format:**

[Drawer #]:[Host Port#] [Link speed] / [Link Status]

**Attached device display format:**

[Drawer#] – [Device slot#]

E.g.

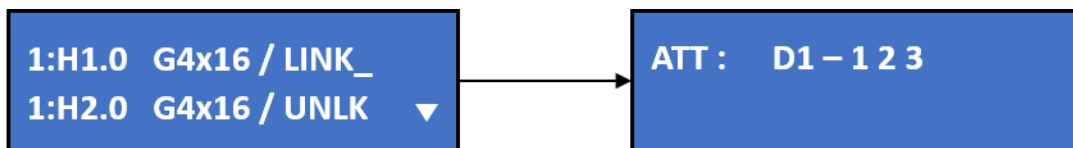

Host 1:H1.0 has the link speed of PCIe Gen4 x16 lanes, linked, and the attached devices are drawer 1 device 1, 2, and 3 (device 1:1, 1:2, 1:3)



## 9.2.8 Health

Users can view PSU status and fan speeds.

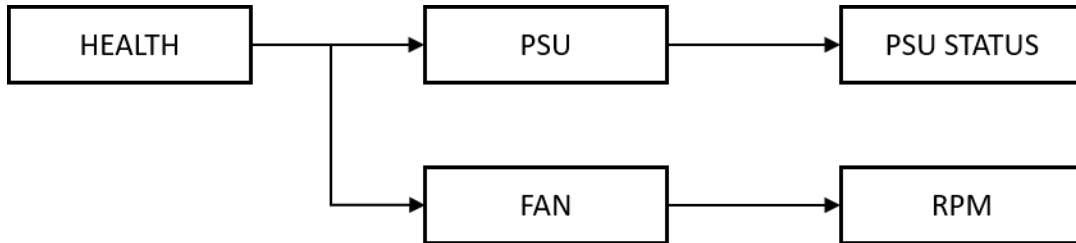

PSU 1 ~ 4

Fan 1-1 ~ 1-3, 2-1 ~ 2-3

*(Chassis rear view)*

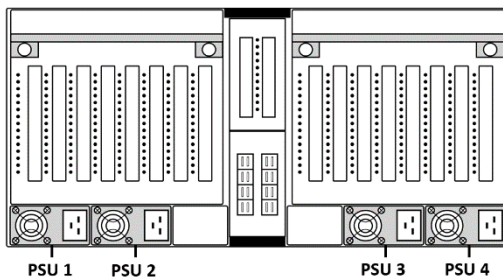

*(Chassis top view)*

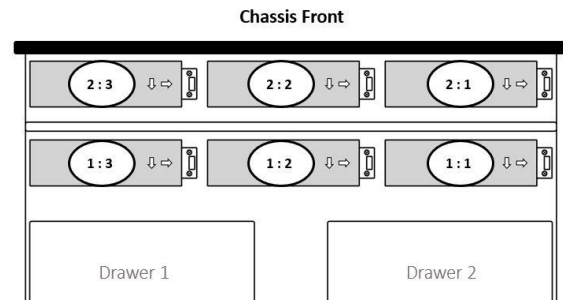

**PSU information display format:**

[PSU#] [status]

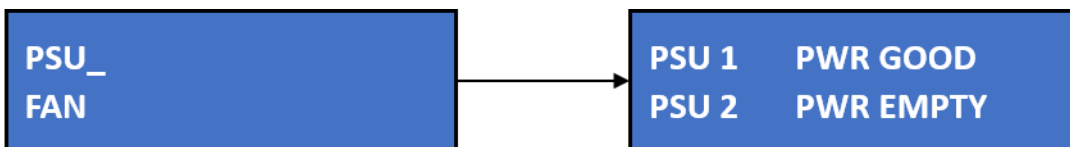

GOOD= PSU is working well

EMPTY= The PSU socket is empty

**Fan information display format:**

[Fan#] [RPM]

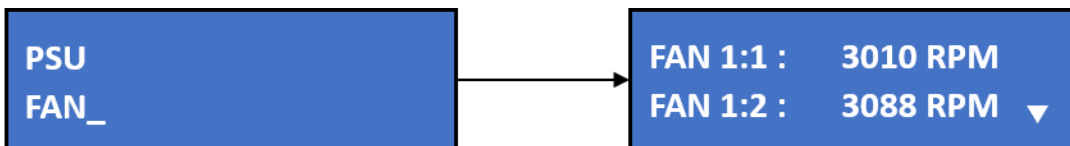

(Press ↓ to see more fans)

## 9.2.9 Temperature

Users can view temperature in degree Celsius of the two Atlas (PCIe switches) and all devices.

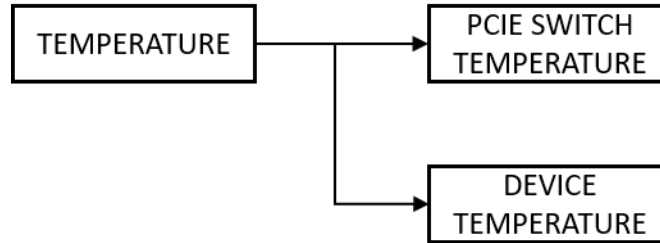

SW1= Atlas 1 (PCIe switch for drawer 1)

SW2= Atlas 2 (PCIe switch for drawer 2)

Device 1:1 ~ 1:4 and 2:1 ~ 2:4

E.g.

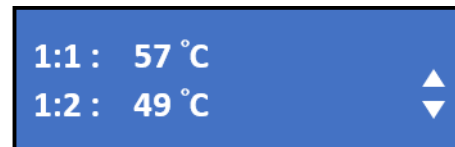
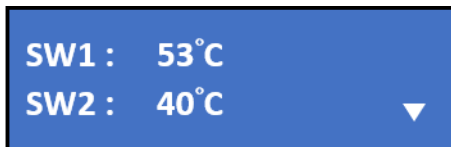

Empty device slot will show 0°C

## 9.2.10 Network

Users can see all the network settings and modify IP address.

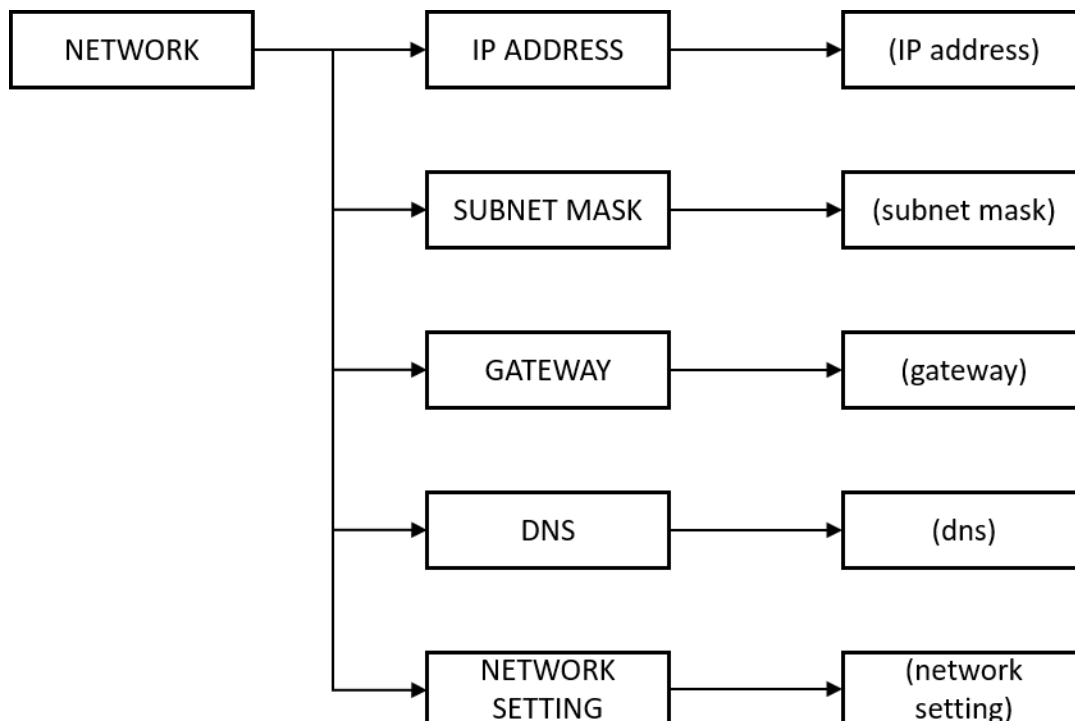

**IP address (read only)**

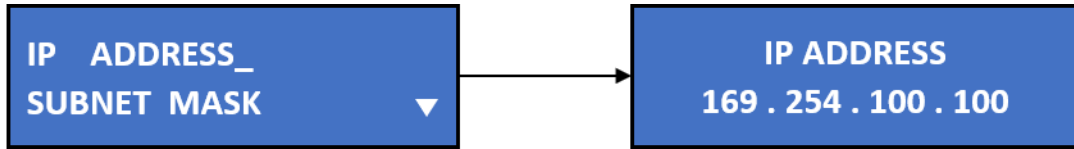

**Subnet mask (read only)**

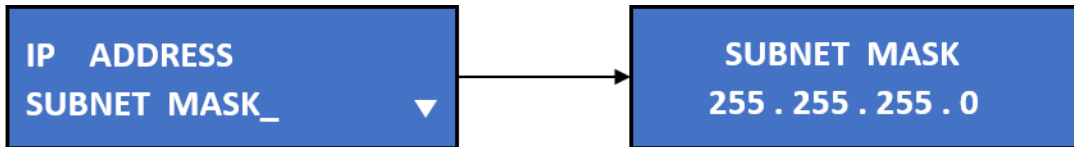

**Gateway (read only)**

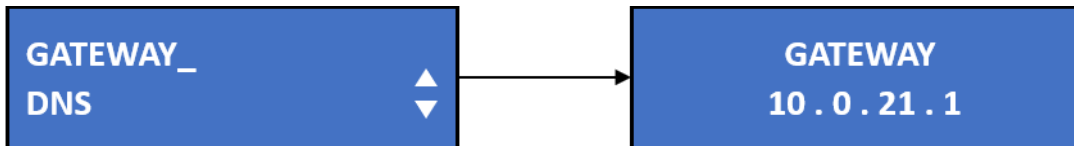

**DNS (read only)**

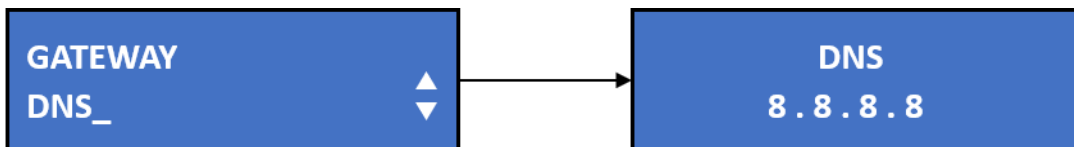

**Network setting**

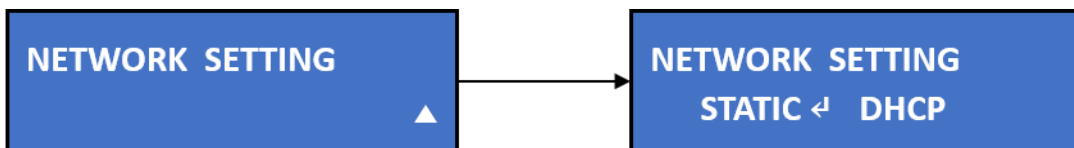

Users can modify IP address from the Network Setting menu

Select **Static** and key in the static IP

Select **DHCP** to generate IP address automatically

## 9.2.11 Password (Feature coming Soon)

Users can modify password.

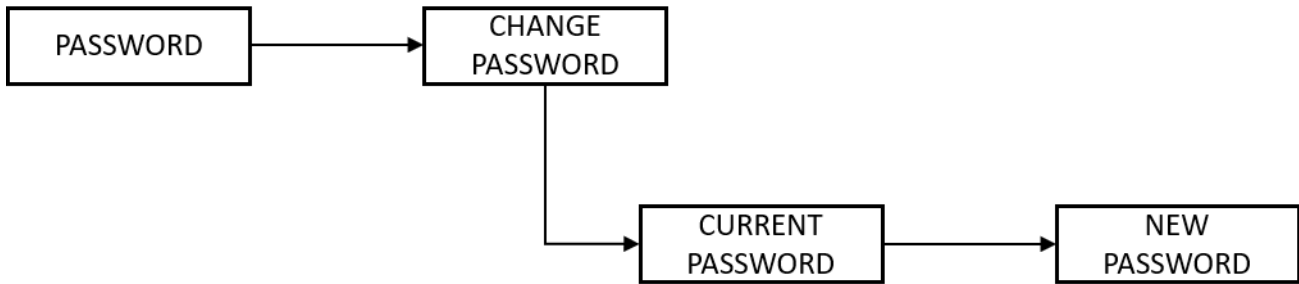

### Password change

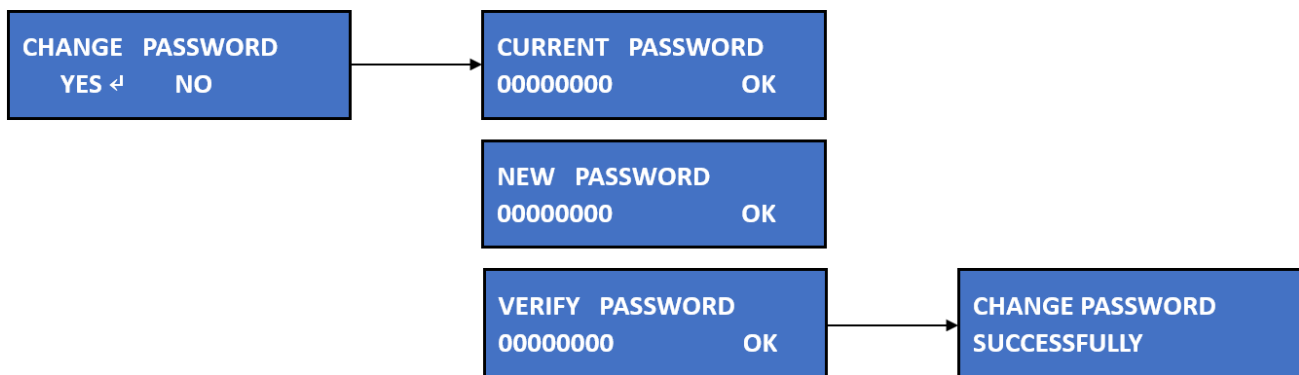

Select "Yes" to change password

Key in the current password

Key in the new password

Verify new password

```
CURRENT PASSWORD
00000000      OK
```

Press ← and → to select digits. The selected digit will flash.

Press ↑ or ↓ to change the numbers for the selected digit.

When all the digits are set, press → to "OK" and press ← to proceed.

Note:

Only numbers 0 ~ 9 available if setting password with this method.

Set your password from the GUI to include alphabets in the password.

## 9.2.12 Reset to default

Users can reset the Falcon 4010 to default.

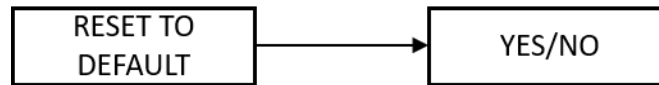

### Reset Process:

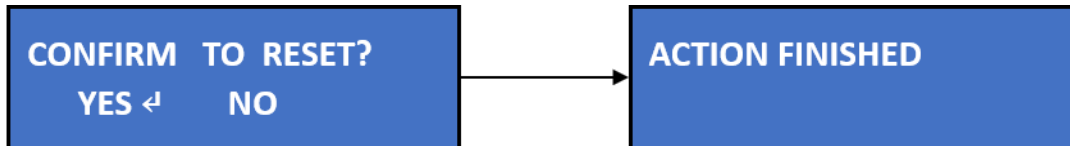

Select “Yes” and the system will start resetting.

“Action finished” will show when the reset is completed.

After reset, the IP address, network gateway, and GUI log-in account will become default.

<b>Default IP address:</b>	169.254.100.100
<b>Default gateway:</b>	0.0.0.0
<b>Log-in username:</b>	admin
<b>Log-in password:</b>	admin

# 10. Operation Safety

Please power-off the entire chassis before opening the top-back cover. Especially when installing/replacing devices for the low-profile slots.

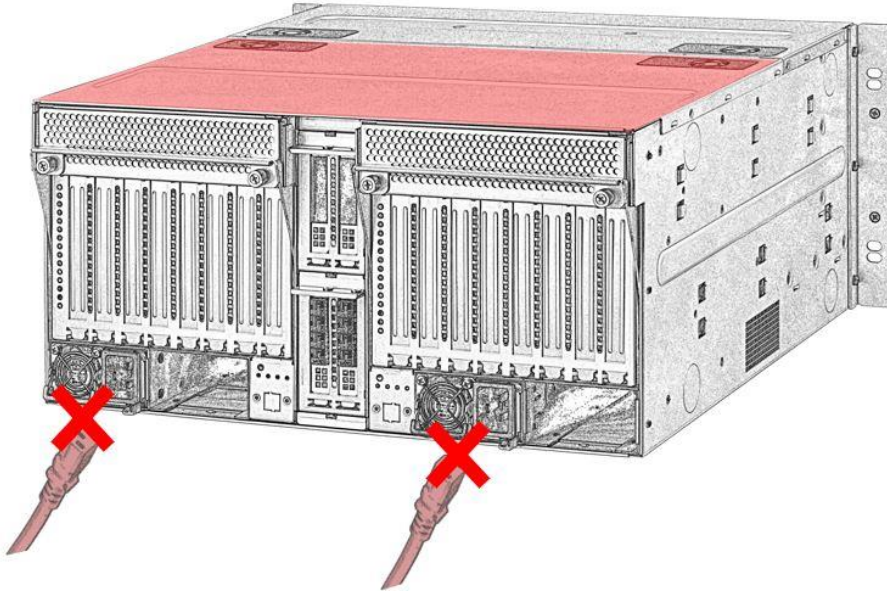

Please power-off the drawers before you draw them out of the chassis

Go to GUI → Chassis (see [P.23](#)) or use LCD power control function (see [P.36](#))  
Power off the drawer to be drawn out.

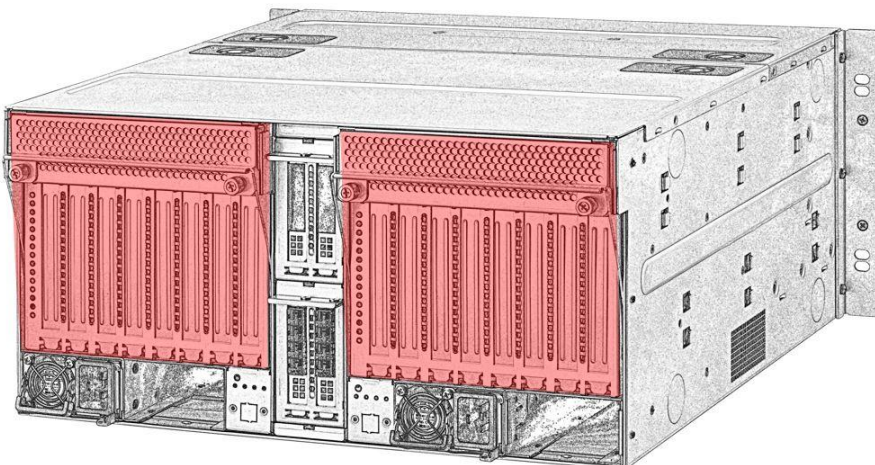
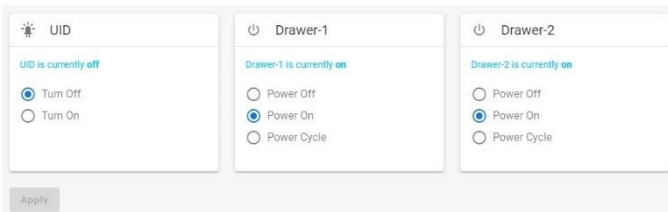

# 11. Trouble Shooting

## Symptoms or Errors

When PCI out of resource and the following warning messages may appear during POST and the server halts:

- **PCI out of resource**
- **PCI resource error**
- **Insufficient PCI resources detected**
- **There is not enough available PCI memory**

## Solution

**Disconnect Falcon 4010 from the host**

**Go to the host BIOS → Advanced settings**

Enable 4G decoding

Set MMIO High Size to 512G or higher

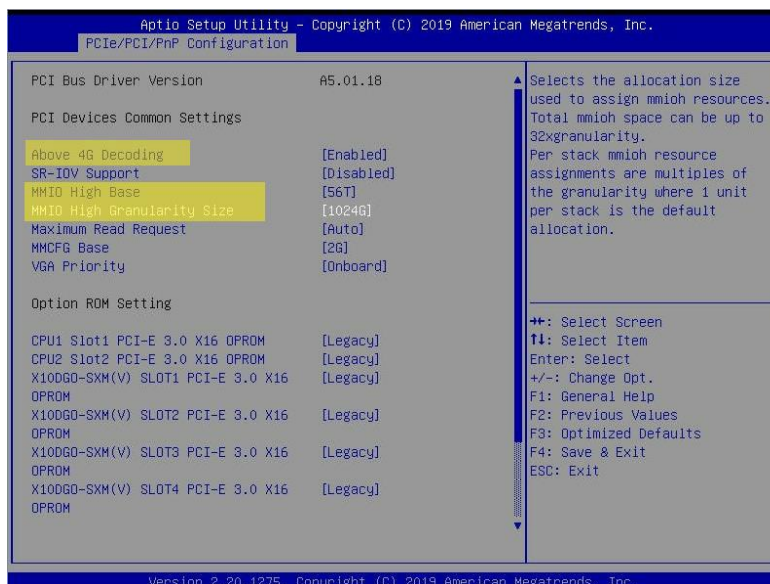

### Specific example: SuperMicro Server

1. Temporarily remove the connection of GPU expansion chassis (unplug connected cable)
2. Go to the BIOS **Advanced**
  - a. Advanced->PCIe/PCI/PnP configuration-> Above 4G Decoding to **Enabled**
  - b. Advanced->PCIe/PCI/PnP Configuration->MMIOHBase to **56T**
  - c. Advanced->PCIe/PCI/PnP Configuration->MMIO High Size to **512G** or higher
3. Connect the GPU expansion chassis to the server and see if the server boots properly

### Specific example: Intel Xeon Phi Server

1. Temporarily remove the connection of GPU expansion chassis (unplug connected cable)

2. Update the BIOS and firmware to the latest revision
3. Go to **Advanced > PCI Configuration**
  - a. Set Maximize Memory below 4 GB to **Disabled**
  - b. Set Memory Mapped I/O above 4 GB to **Enabled**
  - c. Set Memory Mapped I/O Size to **512 G** or higher
4. Connect the GPU expansion chassis to the server and see if the server boots properly

Please visit H3 platform FAQ <https://www.h3platform.com/knowledge-base/faq>  
or contact H3 Platform if you have any question.



# License Model

This document contains information, which is the proprietary property of H3 Platform Inc. This document is received in confidence and its contents may not be disclosed or copied without the prior written consent of H3 Platform Inc.

Nothing in this document constitutes a guarantee, warranty, or license, express or implied. H3 Platform disclaims all liability for all such guarantees, warranties, and licenses, including but not limited to: fitness for a particular purpose; merchantability; not infringement of intellectual property or other rights of any third party or of H3 Platform; indemnity; and all others. The reader is advised that third parties may have intellectual property rights that may be relevant to this document and the technologies discussed herein, and is advised to seek the advice of competent legal counsel, without obligation of H3 Platform.

H3 Platform retains the right to make changes to this document at any time, without notice. H3 Platform makes no warranty for the use of this document and assumes no responsibility for any errors that may appear in the document nor does it make a commitment to update the information contained herein.

Please contact H3 Platform ([sales@h3platform.com](mailto:sales@h3platform.com)) for licensing.